

1.

Atoms of different elements have different properties.

(a) Which of the following is the same for all atoms of the same element?

Tick (✓) **one** box.

Atomic number

Mass number

Neutron number

(1)

(b) Which of the following is different for isotopes of the same element?

Tick (✓) **one** box.

Number of electrons

Number of neutrons

Number of protons

(1)

- (c) A nucleus emits radiation.

Figure 1 shows how the mass number and the atomic number change.

The nucleus is labelled **D**.

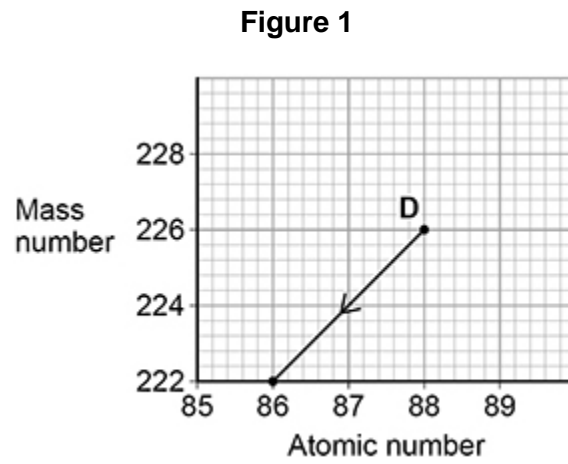

Which type of radiation is emitted when nucleus **D** decays?

Tick (✓) **one** box.

Alpha

Beta

Neutron

(1)

- (d) Nucleus **E** also emits radiation.

Figure 2 shows how the mass number and the atomic number change for nucleus **E**.

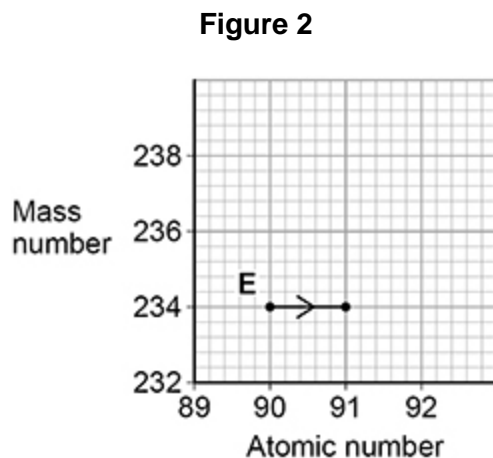

Which type of radiation is emitted when nucleus **E** decays?

Tick (✓) **one** box.

Alpha

Beta

Neutron

(1)

Beta radiation can be used to monitor the thickness of paper during production.

Figure 3 shows how the radiation is used.

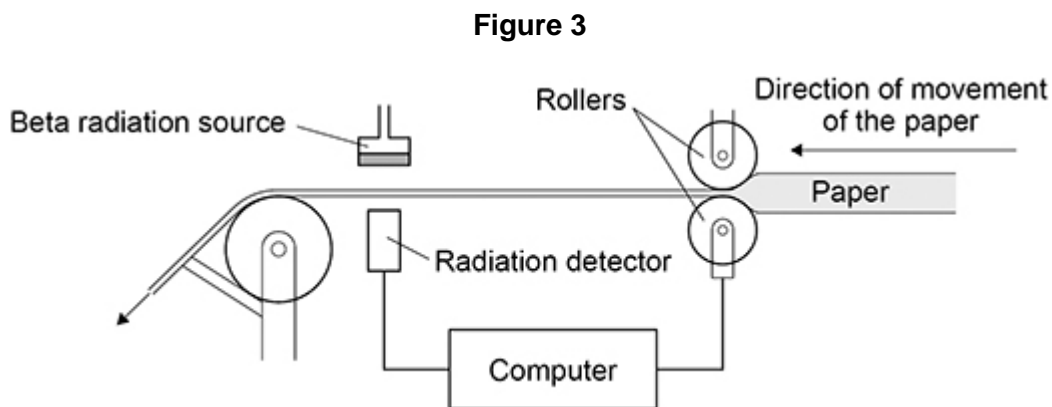

The computer uses information from the radiation detector to change the size of the gap between the rollers.

- (e) Complete the sentences.

Choose answers from the box.

Each answer can be used once, more than once or not at all.

decrease	stay the same	increase
-----------------	----------------------	-----------------

The thickness of the paper between the beta source and the detector increases.

The reading on the detector will _____.

This is because the amount of radiation absorbed by the paper will _____.

(2)

- (f) All radioactive elements have a half-life.

What is meant by 'half-life'?

Tick (✓) **one** box.

The time it takes for all the nuclei in a radioactive sample to split in half.

The time it takes for the count rate of a radioactive sample to halve.

The time it takes for the radiation to travel half of its range in air.

(1)

- (g) Why should the radiation source used in
- Figure 3**
- have a long half-life?

Tick (✓) **one** box.

So the activity of the source is approximately constant.

So the amount of radiation decreases quickly.

So the radiation has a long range in air.

(1)

(Total 8 marks)

2.

Energy from the Sun is released by nuclear fusion.

- (a) Complete the sentences.

Nuclear fusion is the joining together of _____.

During nuclear fusion the total mass of the particles _____.

(2)

- (b) Nuclear fusion of deuterium is difficult to achieve on Earth because of the high temperature needed.

Electricity is used to increase the temperature of 4.0 g of deuterium by 50 000 000 °C.

specific heat capacity of deuterium = 5200 J/kg °C

Calculate the energy needed to increase the temperature of the deuterium by 50 000 000 °C.

Use the Physics Equations Sheet.

Energy = _____ J

(3)

- (c) The idea of obtaining power from nuclear fusion was investigated using models.

The models were tested before starting to build the first commercial nuclear fusion power station.

Suggest **two** reasons why models were tested.

1 _____

2 _____

(2)

- (d) Generating electricity using nuclear fusion will have fewer environmental effects than generating electricity using fossil fuels.

Explain **one** environmental effect of generating electricity using fossil fuels.

(2)

(Total 9 marks)

3.

Radioactive waste from nuclear power stations is a man-made source of background radiation.

- (a) Which of the following is also a man-made source of background radiation?

Tick (✓) **one** box.

cosmic rays

radiotherapy

rocks

stars

(1)

- (b) Nuclear power stations use the process of nuclear fission.

Complete the sentences to describe the process of nuclear fission.

Choose answers from the box.

a neutron	a proton	an electron	
cosmic rays	energy	gamma rays	x-rays

An unstable nucleus absorbs _____ and splits into two parts.

Two or three neutrons are released, as well as _____

and _____.

(3)

- (c) Plutonium-239 is one type of radioactive waste from nuclear power stations.

The following nuclear equation represents the decay of plutonium-239 (Pu-239).

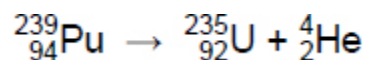

How does the nuclear equation show that alpha radiation is emitted when plutonium-239 decays?

Tick (✓) **one** box.

An alpha particle contains 92 protons.

An alpha particle has a mass number of 235.

An alpha particle is the same as a helium nucleus.

(1)

The graph below shows how the activity of a sample of plutonium-239 varies with time.

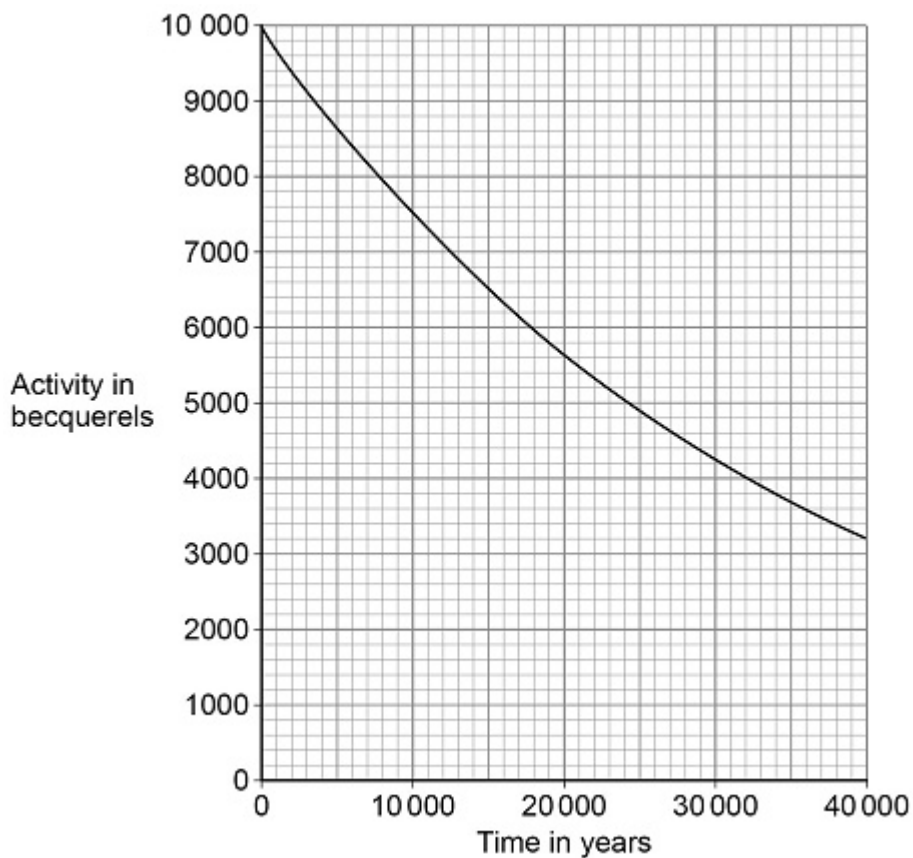

- (d) How much time will it take for the activity of the sample of plutonium-239 to fall to half of its initial activity?

Time = _____ years

(1)

- (e) What is the half-life of plutonium-239?

Half-life = _____ years

(1)

- (f) The radioactive waste from a nuclear power station is buried underground.

People are warned to stay away from places where radioactive waste is buried.

Suggest **one** risk of going near the place where radioactive waste is buried.

(1)

(Total 8 marks)

4.

Polonium-210 (${}_{84}^{210}\text{Po}$) is a radioactive isotope that decays by emitting alpha radiation.

- (a) Which is the correct decay equation for polonium-210?

Tick (✓) **one** box.

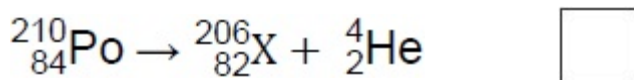
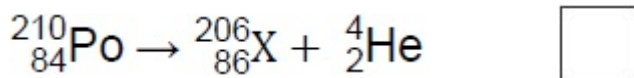
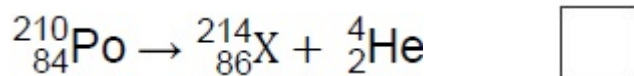

(1)

(b) Why is alpha radiation dangerous inside the human body?

Tick (✓) **one** box.

Alpha radiation is electromagnetic radiation.

Alpha radiation is highly ionising.

Alpha radiation is very penetrating.

(1)

The figure below shows how the mass of a sample of polonium-210 changes with time.

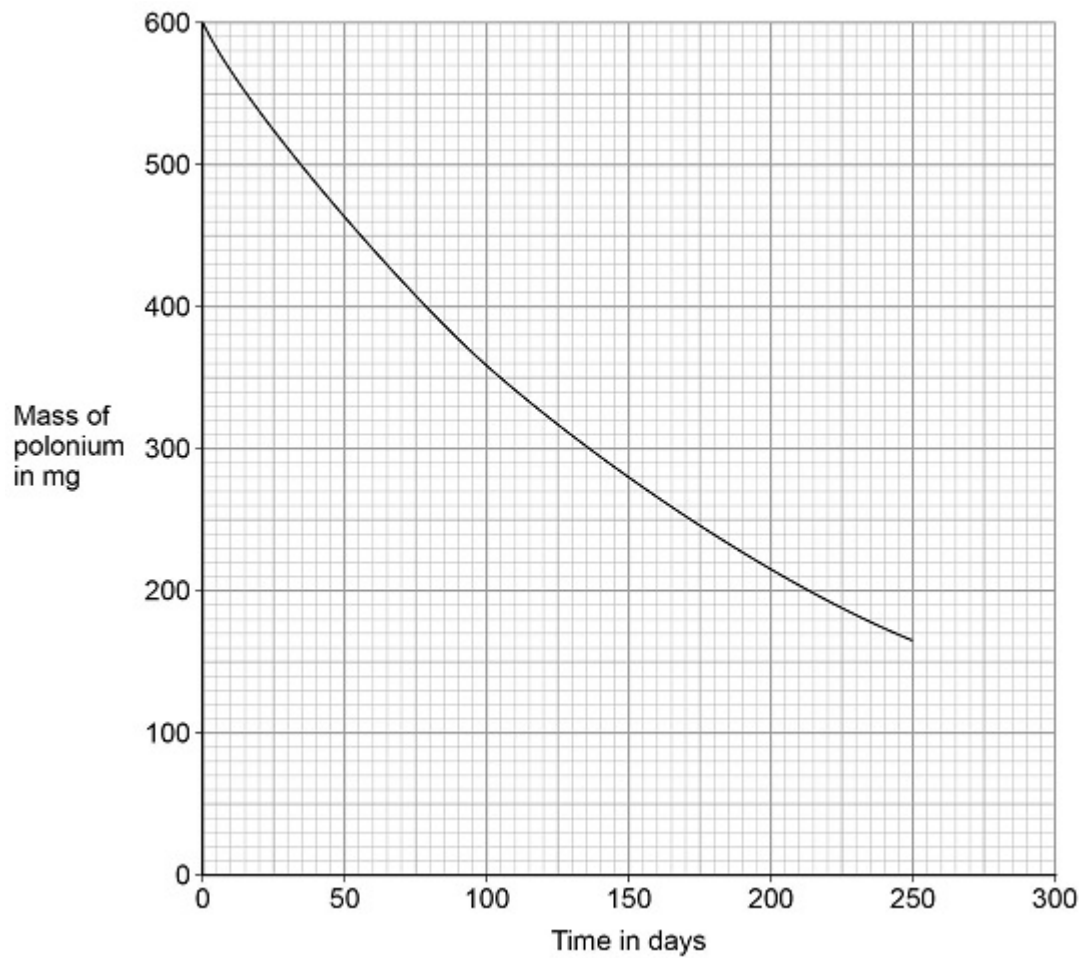

- (c) Determine the change in mass of the sample of polonium-210 between 50 and 150 days.

Change in mass = _____ mg

(2)

- (d) Estimate the mass of polonium-210 remaining after 300 days.

Mass = _____ mg

(1)

- (e) Nuclear radiation can cause ionisation.

Complete the sentences.

Choose answers from the box.

a negative an electron a neutron a positive a proton a zero

An atom becomes an ion when it loses _____.

The resulting ion has _____ charge.

(2)

(Total 7 marks)

- 5.** The ancient Greeks thought that atoms were tiny spheres that could not be divided into anything smaller.

Since then, different discoveries have led to the model of the atom changing.

Some of the discoveries are given in the table below.

The mass of an atom is concentrated in the nucleus.	A
Electrons orbit the nucleus at specific distances.	B
The nucleus contains neutrons.	C
The nucleus contains positively charged protons.	D

- (a) Which discovery was the earliest?

Tick (✓) **one** box.

A

B

C

D

(1)

- (b) Which discovery was the most recent?

Tick (✓) **one** box.

A

B

C

D

(1)

- (c) The alpha particle scattering experiment led to the nuclear model of the atom.

The figure below shows the paths of alpha particles travelling close to a gold nucleus.

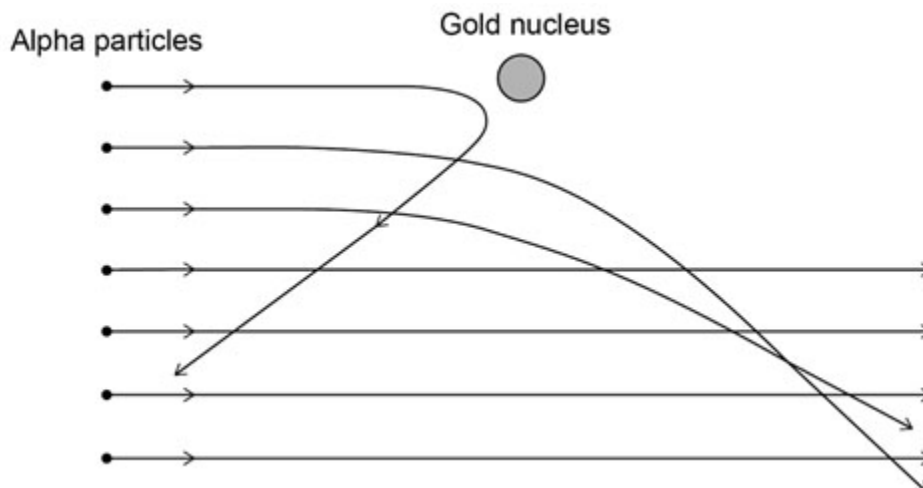

Complete the sentences.

Choose answers from the box.

Each answer may be used once, more than once or not at all.

attracts	decreases	does not change
increases	reflects	repels

Alpha particles and gold nuclei are both positively charged.

The gold nucleus _____ the alpha particles.

As the alpha particle approaches the gold nucleus, the electric field strength experienced by the alpha particle _____.

As an alpha particle approaches the gold nucleus, the force experienced by the alpha particle _____.

- (d) The results of the alpha particle scattering experiment were reproducible.

What does reproducible mean?

Tick (✓) **one** box.

Another scientist repeats the experiment and gets the same results.

Another scientist repeats the experiment and gets different results.

The same scientist repeats the experiment and gets the same results.

The same scientist repeats the experiment and gets different results.

(1)

(Total 6 marks)

6.

Americium-241 (${}_{95}^{241}\text{Am}$) is an isotope of americium.

- (a) Which of the isotopes given in the table below is **not** an isotope of americium?

Isotope	Mass number	Atomic number
A	243	95
B	243	94
C	242	95

Isotope _____

Give a reason for your answer.

(2)

The graph below shows how the number of americium-241 nuclei in a sample changes with time.

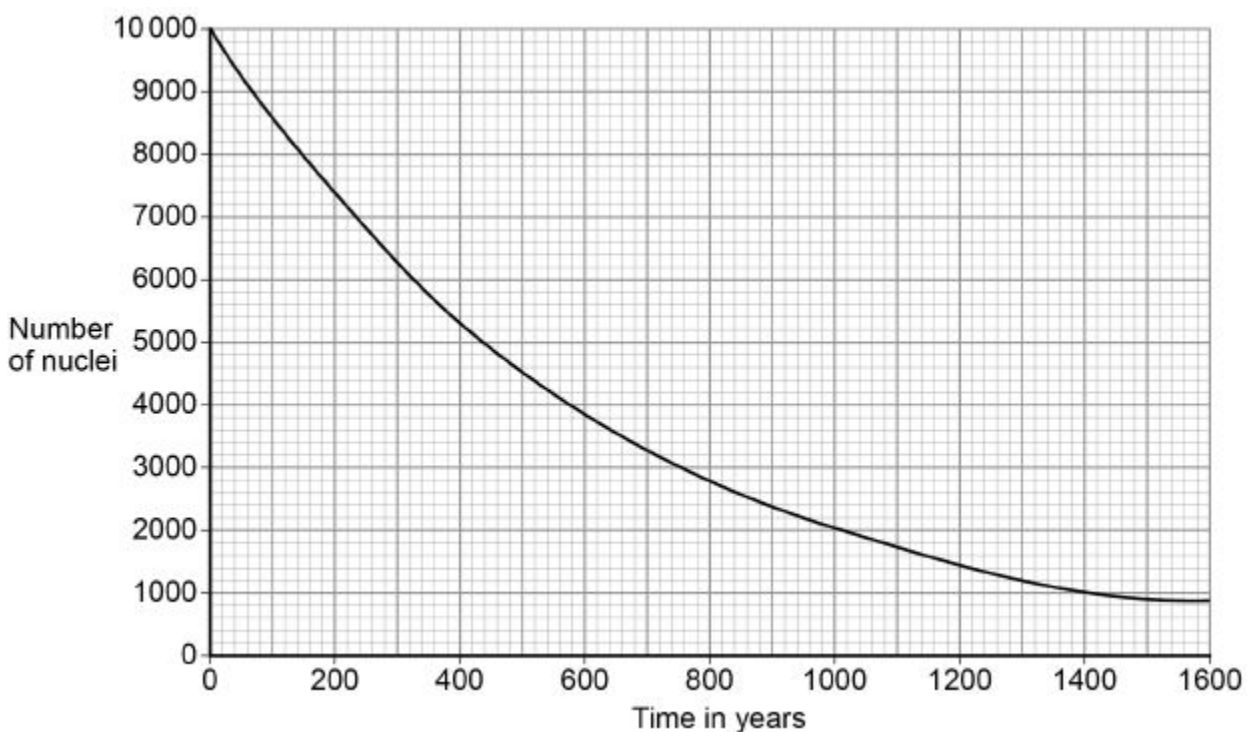

- (b) How many years does it take for the number of americium-241 nuclei to decrease from 10 000 to 5000?

Time = _____ years

(1)

- (c) What is the half-life of americium-241?

Half-life = _____ years

(1)

(Total 4 marks)

7.

Nuclear power can be used to generate electricity through nuclear fission.

Figure 1 shows the process of nuclear fission.

Figure 1

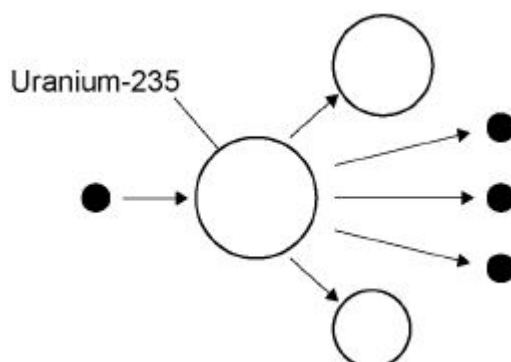

- (a) Complete the sentences.

Choose answers from the box.

gamma rays	light rays	proton	neutron	nucleus	X-rays
-------------------	-------------------	---------------	----------------	----------------	---------------

During the process of nuclear fission, a uranium _____

absorbs a _____ .

Electromagnetic radiation is released in the form of _____ .

(3)

- (b) The UK needs at least 25 000 000 kW of electrical power at any time.

A nuclear power station has an electrical power output of 2 400 000 kW

Calculate how many nuclear power stations are needed to provide 25 000 000 kW of electrical power.

Number of nuclear power stations = _____

(2)

- (c) State **two** environmental issues caused by generating electricity using nuclear power stations.

1. _____

2. _____

(2)

- (d) The UK currently generates a lot of electricity by burning natural gas. This process releases carbon dioxide into the atmosphere.

Figure 2 shows how the concentration of carbon dioxide in the atmosphere has changed over the past 115 years.

Figure 2

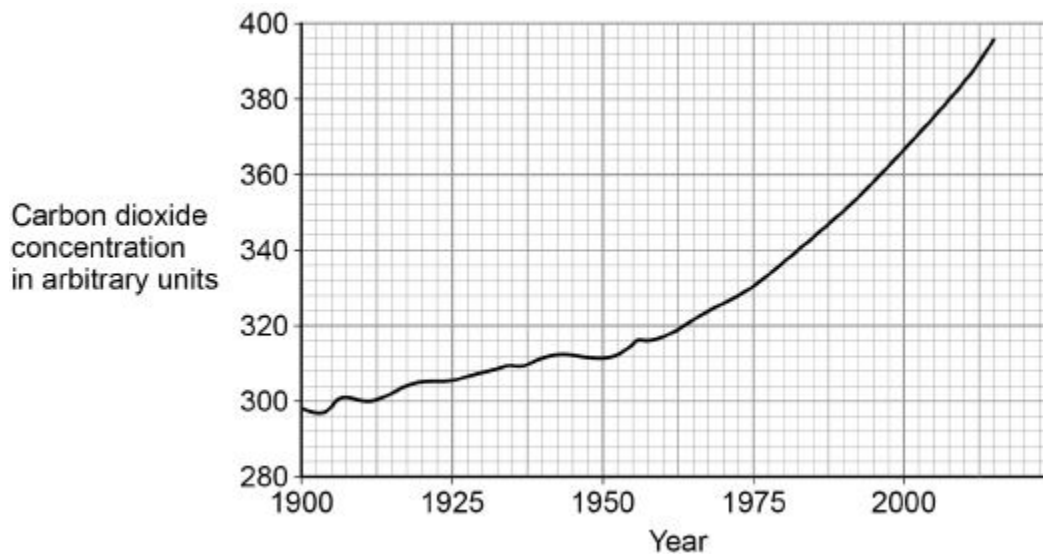
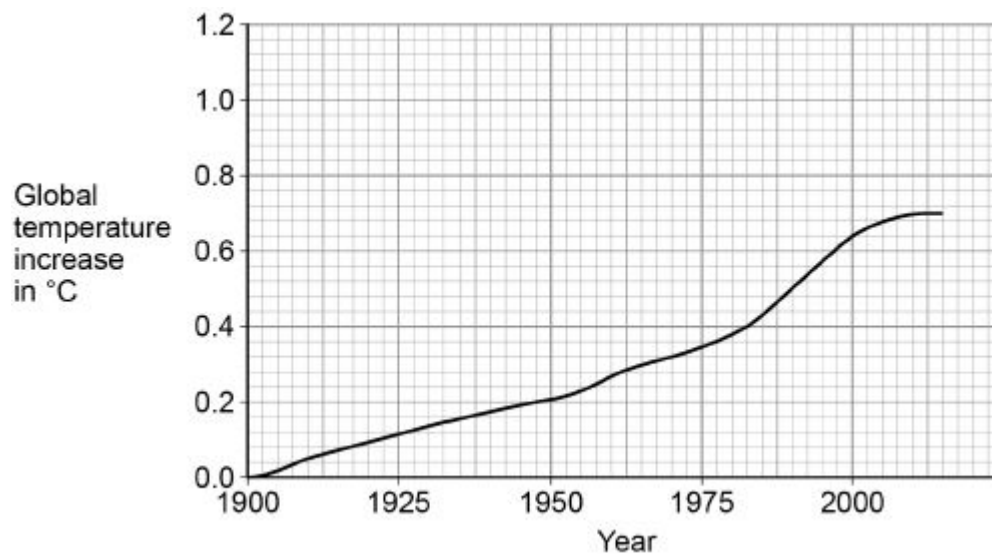

Figure 3 shows how the global temperature has changed over the past 115 years.

Figure 3



Give **one** similarity and **one** difference between the data in **Figure 2** and **Figure 3**.

Similarity _____

Difference _____

(2)

(Total 9 marks)

8.

A teacher used a Geiger-Muller tube and counter to measure the number of counts in 60 seconds for a radioactive rock.

- (a) The counter recorded 819 counts in 60 seconds. The background radiation count rate was 0.30 counts per second.

Calculate the count rate for the rock.

Count rate = _____ per second

(3)

- (b) A householder is worried about the radiation emitted by the granite worktop in his kitchen.

1 kg of granite has an activity of 1250 Bq. The kitchen worktop has a mass of 180 kg.

Calculate the activity of the kitchen worktop in Bq.

Activity = _____ Bq

(2)

- (c) The average total radiation dose per year in the UK is 2.0 millisieverts.

The table below shows the effects of radiation dose on the human body.

Radiation dose in millisieverts	Effects
10 000	Immediate illness; death within a few weeks
1000	Radiation sickness; unlikely to cause death
100	Lowest dose with evidence of causing cancer

The average radiation dose from the granite worktop is 0.003 millisieverts per day.

Explain why the householder should **not** be concerned about his yearly radiation dose from the granite worktop.

One year is 365 days.

(2)

- (d) Bananas are a source of background radiation. Some people think that the unit of radiation dose should be changed from sieverts to Banana Equivalent Dose.

Suggest **one** reason why the Banana Equivalent Dose may help the public be more aware of radiation risks.

(1)

(Total 8 marks)

9.

The diagram shows a lithium atom.

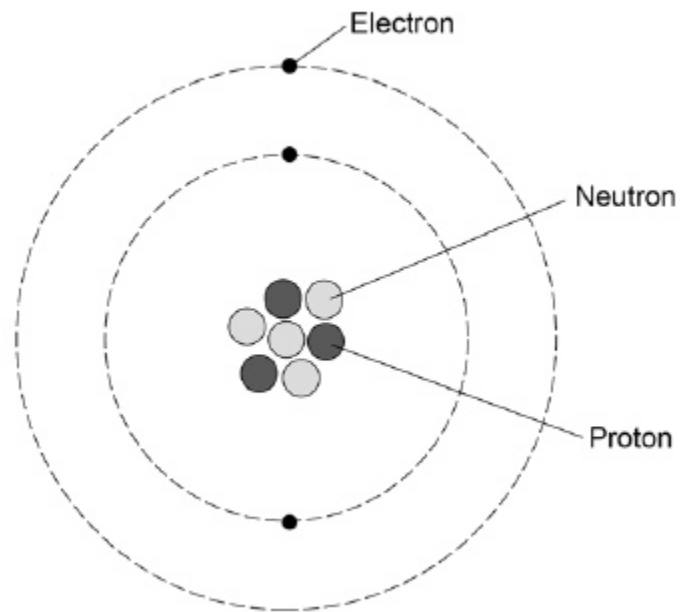

(a) What is the mass number of this lithium atom?

Tick **one** box.3 4 7 10

(1)

(b) What is the atomic number of a lithium atom?

Tick **one** box.3 4 7 10

Give a reason for your answer.

(2)

- (c) Complete the sentence.

Choose the answer from the box.

circles	levels	rings
----------------	---------------	--------------

The electrons in an atom orbit in different energy _____.

(1)

- (d) Some atomic nuclei are unstable and decay by emitting an alpha particle or a beta particle.

Complete the symbols for an alpha particle and a beta particle.

Use answers from the box.

-1	0	1	2	4
-----------	----------	----------	----------	----------

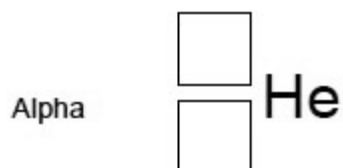

(3)

- (e) Doctors may use nuclear radiation to diagnose certain types of illness.

The table below gives data about three radiation sources used.

Each source emits beta radiation.

Radiation source	Half-life in minutes
Carbon-11	20
Nitrogen-13	10
Oxygen-15	2

Explain why oxygen-15 is likely to pose the least risk to a patient.

(2)

(Total 9 marks)

10.

Sources of background radiation are either natural or man-made.

(a) Which **two** of the sources listed in the table are natural sources of background radiation?

Tick **two** boxes.

Cosmic rays

Medical X-rays

Nuclear power stations

Nuclear weapons testing

Radon gas

(2)

A teacher used a Geiger-Müller (GM) tube and counter to measure the background radiation in his laboratory.

Figure 1 shows the GM tube and counter.

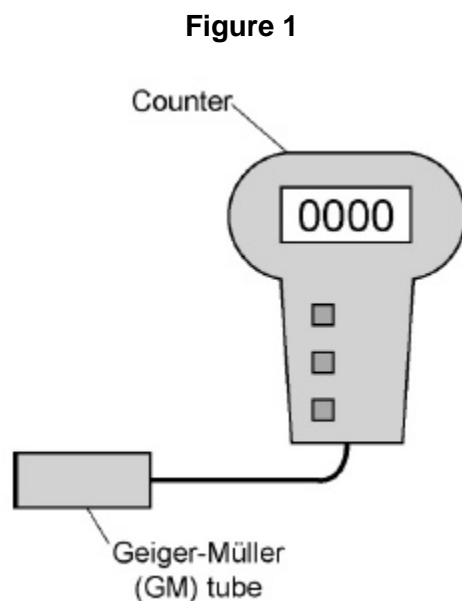

- (b) The table gives three readings taken by the teacher at three different times on the same day.

Counts in 1 minute
16
21
18

What is the most likely reason for the readings being different?

Tick **one** box.

Radioactive decay is a random process.

The air pressure in the laboratory increased.

The background radiation increased during the day.

The temperature in the laboratory decreased.

- (c) The teacher takes a radioactive source from a storage box.

Figure 2 shows the box.

Figure 2

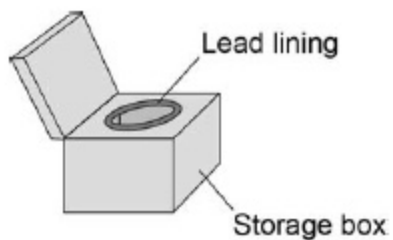

Why does storing the radioactive source in the box reduce the risk of radiation exposure to the teacher?

Tick **one** box.

The lead lining absorbs the emitted radiation.

The lead lining reflects the emitted radiation.

The lead lining transmits the emitted radiation.

(1)

- (d) **Figure 3** shows how the teacher used the GM tube and counter to measure the radiation emitted from the radioactive source.

The counter was reset to zero.

The count after one minute was 159.

Figure 3

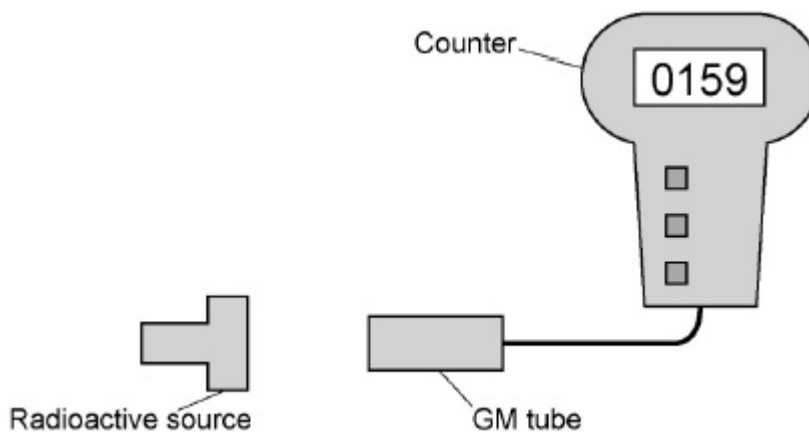

How should the teacher calculate the counts from the radioactive source?

Tick **one** box.

Add the background count to 159

Divide the background count by 159

Multiply the background count by 159

Subtract the background count from 159

(1)

- (e) The teacher passed the radiation through an electric field.

Figure 4 shows the path that the radiation took through the electric field.

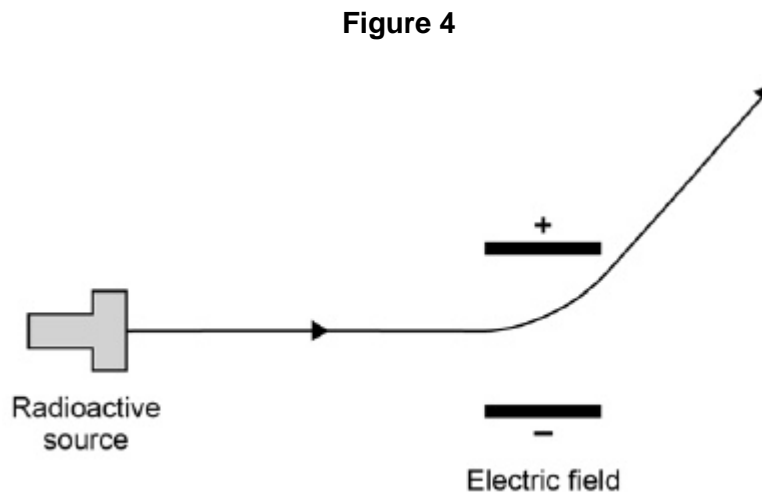

What type of radiation was being emitted by the radioactive source?

Tick **one** box.

Alpha

Beta

Gamma

Neutron

Explain the reason for your answer.

(3)

(Total 8 marks)

11.

Alpha, beta and gamma are types of nuclear radiation.

(a) Draw **one** line from each type of radiation to what the radiation consists of.

Type of radiation	What radiation consists of
Alpha	Electron from the nucleus
Beta	Two protons and two neutrons
Gamma	Electromagnetic radiation
	Neutron from the nucleus

(3)

- (b) A teacher demonstrates the penetration of alpha, beta and gamma radiation through different materials.

The demonstration is shown in the figure below.

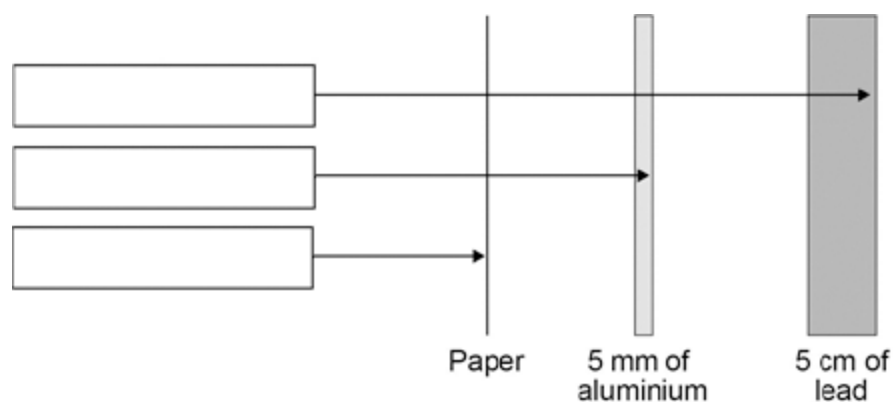

Complete the figure above by writing the name of the correct radiation in each box.

(2)

- (c) Give **two** safety precautions the teacher should have taken in the demonstration.

1. _____

2. _____

(2)

- (d) The table below shows how the count rate from a radioactive source changes with time.

Time in seconds	0	40	80	120	160
Count rate in counts/second	400	283	200	141	100

Use the table to calculate the count rate after 200 seconds.

(2)

