

Q1.Figure 1 shows a circuit that includes an ideal operational amplifier. A student uses this circuit to amplify the signal from the sensor before further processing by the system.

Figure 1

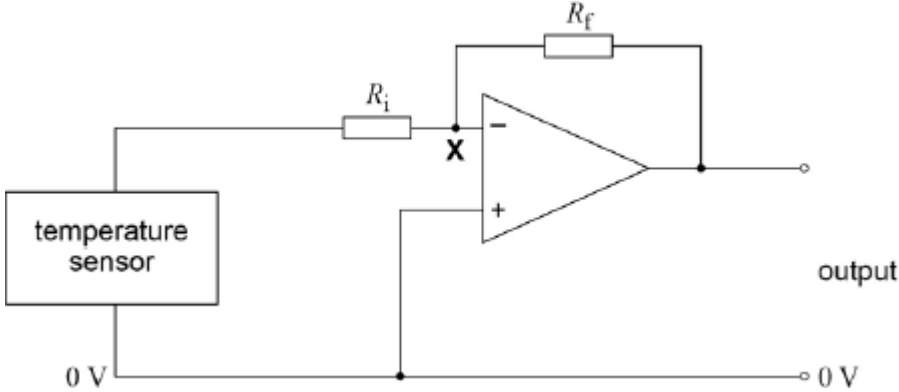

(a) Point X in **Figure 1** is said to be a virtual earth.

Explain the meaning of the term virtual earth in this type of circuit.

.....

.....

.....

(2)

(b) The temperature sensor produces a signal that changes by 10 mV for every degree Celsius change in temperature. The signal is 0 mV when the temperature of the sensor is 0 °C

The value of R_i is 22 kΩ and the value of R_f is 270 kΩ.

Calculate the output voltage V_{OUT} of the circuit in **Figure 1** when the sensor is at a temperature of 50 °C.

$V_{OUT} = \dots\dots\dots V$

(2)

- (c) The circuit is powered by a $-15\text{ V} - 0 - +15\text{ V}$ supply. Explain why this circuit will not detect temperatures above $122\text{ }^{\circ}\text{C}$.

.....

.....

.....

.....

(2)

- (d) A student suggests a modification to the circuit in **Figure 1** to form a difference amplifier circuit for a thermostat. The modified circuit is shown in **Figure 2**.

Figure 2

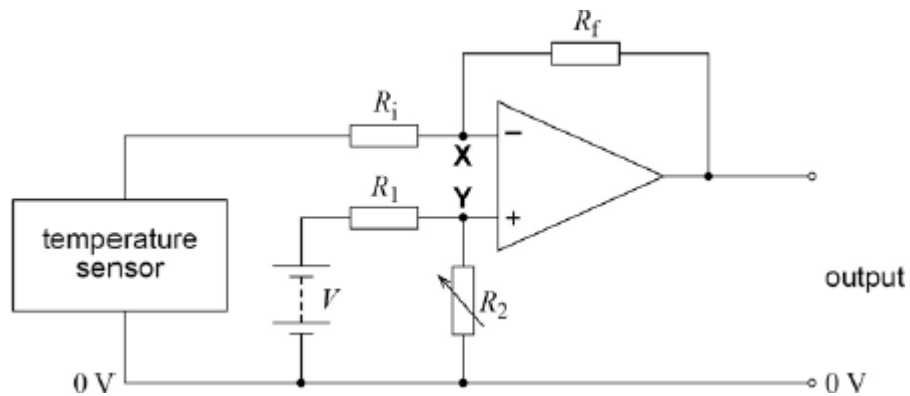

The output controls a circuit that switches the heater off when the output is positive.

Explain how this circuit operates so that the heater switches off when the temperature reaches a pre-determined level.

.....

.....

.....

.....

.....

.....

(3)
(Total 9 marks)

Q2.Figure 1 shows the circuit of a summing amplifier which uses an operational amplifier with *negative feedback*. The power supply to the operational amplifier is $\pm 12\text{ V}$.

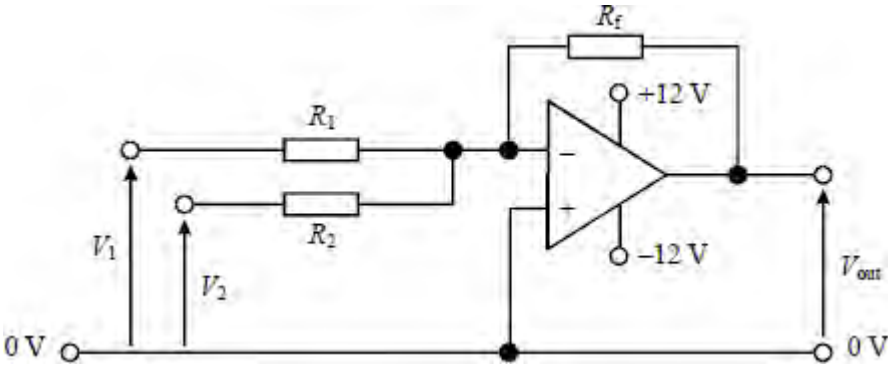

Figure 1

- (a) (i) State what is meant by negative feedback. Explain how this is achieved in the above circuit.

.....

- (ii) Give **two** reasons for using negative feedback in an amplifier.

.....

(4)

- (b) The input voltages to the amplifier in part (a), V_1 and V_2 , vary with time according to the graphs shown in **Figure 2**. Given that $R_1 = 40\text{ k}\Omega$, $R_2 = 20\text{ k}\Omega$ and $R_f = 40\text{ k}\Omega$ show on the third set of axes the variation of V_{out} with time. Indicate values of V_{out} on the axis.

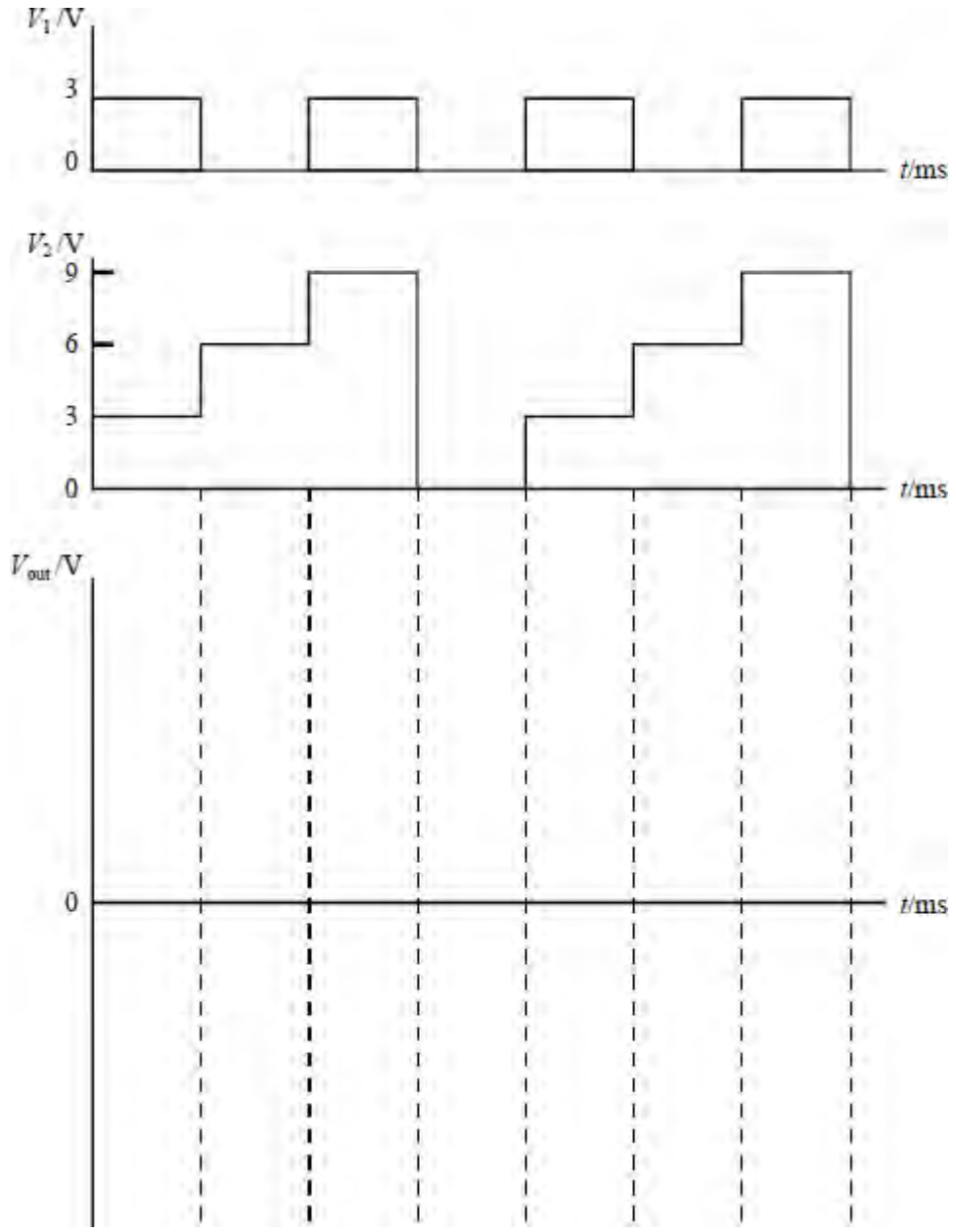

Figure 2

.....

.....

.....

(4)
(Total 8 marks)

Q3.

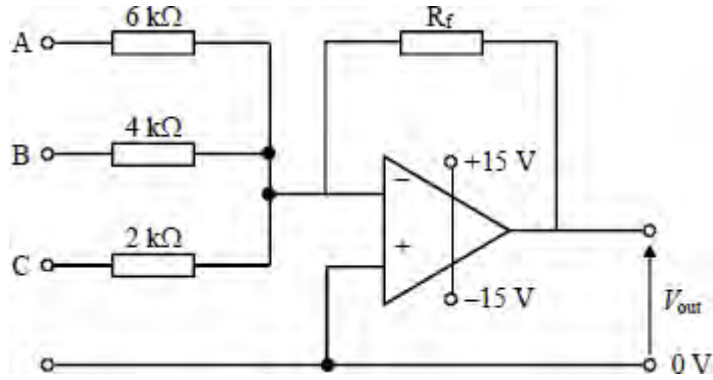

In the circuit shown, an input of +1.2 V is applied simultaneously to each of the inputs A, B and C.

- (a) Determine the current flowing through each of the input resistors and mark on the diagram the direction of each current.

.....

.....

.....

.....

- (b) Determine the value of the output voltage, V_{out} , if $R_f = 10\text{ k}\Omega$.

.....

.....

.....

- (c) If R_f is changed to a resistor of 20 kΩ state, with a reason, the value of V_{out} .

.....

.....

(Total 6 marks)