

## Mark schemes

1.

- (a) finds  $d$  by reading position of (lower end of) detector;  
subtracts 138 mm or writes  $1\checkmark$

for  $1\checkmark$  allow 'reads / measures height of detector' / 'distance from detector to bench';

reject 'measures height of clamp'  $\mathbf{T}$

if 'subtracts 138' is not seen; allow

'subtract distance from source to bench' / 'between source and bench' / 'height of source from ground' / 'position of top / open end / mouth of source';

allow 'measures height of the detector and the source and finds difference';

condone 'reversed' subtraction

annotates **Figure 1** to show suitable use of a recognisable set-square  $2\checkmark$

for  $2\checkmark$  expect a triangular  $90^\circ$  set-square in contact with a vertical edge of the ruler, top edge aligned with open end of the detector, eg

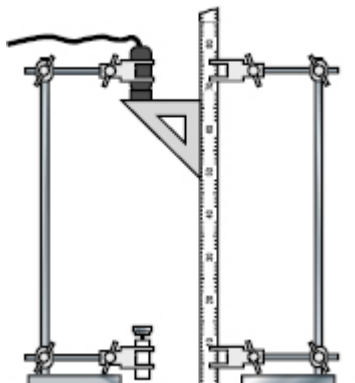

condone use of recognisable T-square in contact with vertical edge etc

2

- (b) background count rate correct  $1\checkmark$

for  $1\checkmark$  accept any of:

$$\text{background count rate} = 0.7(0) / \frac{630}{900} (\text{s}^{-1})$$

OR

$$\text{background count in } 100 \text{ s} = 70$$

OR

$$\text{background count in } 300 \text{ s} = 210$$

1

working leading to correct  $R_C$   $2\checkmark$

$$\text{for } 2\checkmark [\text{cao}] \geq 2 \text{ sf } R_C = 0.33 (\text{s}^{-1})$$

reject  $R_C = 0.30$  if their uncorrected count has been rounded to 1.0

1

(c) attempts two calculations that would lead to a conclusion  $_1\checkmark$

for  $_1\checkmark$  the result of at least one calculation of  $d^2 \times R_C$  or of  $d \times \sqrt{R_C}$  must be correct to 2 sf (see table) otherwise withhold both marks;

allow use of  $d$  in m but reject POT error;

allow 1 sf  $d^2 \times R_C$  for use of  $R_C = 0.3$ ;

allow  $530^2 \times$  their (b) result

a reasoned judgement that the evidence does not support the prediction  $_2\checkmark$

$d / \text{mm}$	380	530	$\Delta\%$
$R_C / \text{s}^{-1}$	0.76	0.33	
$d^2 \times R_C$	$1.1(0) \times 10^5$	$9.27 \times 10^4$	18%
$d \times \sqrt{R_C}$	331 / 330	305 / 310	8.4%

$d / \text{mm}$	380	530	$\Delta\%$
$R_C / \text{s}^{-1}$	0.76	0.3 (1 sf)	
$d^2 \times R_C$	$1.1(0) \times 10^5$	$8(.43) \times 10^4$	29%
$d \times \sqrt{R_C}$	331 / 330	$3.(0) \times 10^2$	14%

for  $_2\checkmark$  two correct calculations of  $d^2 \times R_C$  or  $d \times \sqrt{R_C}$ , both must be correct to 2 sf

OR

one correct calculation of  $d^2 \times R_C$  or of  $d \times \sqrt{R_C}$  correct to 2 sf and an appropriate reverse-working calculation;

the statement rejecting the prediction should be supported by a calculation of the percentage difference between the results of their calculations (see  $\Delta\%$  in table);

condone weaker 'large' / 'significant differences' (between calculation results);

reject 'prediction not correct' because 'values are different' / 'not constant' / 'not close enough'

- (d) lower / adjust the position of the detector / clamp **T**<sub>1</sub>✓

*for* <sub>1</sub>✓ *condone 'lower clamp' (this implies clamp **T** since **B** cannot be lowered further)*

*allow 'remove source using tongs while adjusting detector / clamp **T** otherwise* <sub>2</sub>✗

1

to maximise distance between the experimenter and the source or wtte

OR

to reduce (limit) exposure (time) of the experimenter to radiation or wtte <sub>2</sub>✓

*for* <sub>2</sub>✓ *allow 'not going (too) close (to source)'*

*reject 'don't touch / make contact with source'*

*suggesting using lead shielding is neutral*

*allow* <sub>12</sub>✓ *for 'remove source or wtte using tongs to maximise distance etc before moving **B** upwards'*

*changes to the position of source / clamp **B** without the use of tongs loses both marks*

1

- (e) determines  $10^a - 10^b$  where  $a$  and  $b$  are (any) plotted values of  $\log(d / \text{mm})$  <sub>1</sub>✓

use of  $\Delta d = \frac{10^a - 10^b}{n}$  where  $n$  is 1, 2, 3 or 4;

$\Delta d$  in range 47(.0) to 53(.0) (mm) <sub>2</sub>✓

*insist on  $a$  and  $b \geq 2$  dp; allow read-off errors  $\pm$  one square;*

*expect*  $\frac{10^{2.52} - 10^{2.11}}{4} = 50(.6)$  (mm);

*allow* <sub>12</sub>✓ *for*  $\frac{e^a - e^b}{n}$  *leading to  $\Delta d$  correct for their values*

*<sub>2</sub>✓ is contingent on <sub>1</sub>✓ ie there is no credit for an unsupported answer*

2

(f) suitable analysis  $_1\checkmark$

for  $_1\checkmark \log R_C = -2 \log d + \log k$  seen; minus sign essential

1

appropriate use of **Figure 2**  $_2\checkmark$

for  $_2\checkmark$  draw best-fit line **and** measure gradient;

allow implication that a (linear) best-fit line is drawn and the gradient is being measured, eg 'check gradient of best-fit line';

condone  $m = \text{gradient}$

1

processing and conclusion  $_3\checkmark$

for  $_3\checkmark$  states that the prediction is confirmed if the gradient /  $m$  is  $\approx -2$

OR

prediction is **not** confirmed if the gradient is  $\neq -2$

condone 'the gradient should be  $-2$  (to confirm prediction)'

(**no** ECF for  $m = (+)2$  if denied in  $_1\checkmark$  for missing  $-$  sign)

allow  $_{123}\checkmark$  prediction is **not** confirmed if the best-fit line is a curve  
reject 'prediction is confirmed if the best-fit line is straight' / 'there is a negative gradient' / 'because  $k$  is constant'

1

(g)  $t_d = 1.96 \times 10^{-4}$  (s)  $\checkmark$

minimum 2 sf; accept  $196 \mu\text{s}$ ;

calculation should be  $\frac{102 - 100}{102 \times 100}$  so only accept

$2.0 \times 10^{-4}$  (s) /  $200 \mu\text{s}$  only if **rounding up**

( $\frac{100 - 98}{100 \times 98}$  gives  $t_d = 2.04 \times 10^{-4}$  (s))

1

(h) random nature of decay or wtte  $_1\checkmark$

*for  $_1\checkmark$  condone 'the source emits (photons) sporadically' / 'unpredictably';*

*reject explanation based on exponential decay*

*reject 'decay occurs by chance' / 'source does not emit photons at a constant rate' / 'photons decay' / 'decay is spontaneous / inconsistent'*

1

idea that more than one photon may arrive per 0.01 s interval

OR

idea that no photon may arrive during per 0.01 s interval

OR

photons 'arrive randomly' / 'do not arrive at a steady rate or wtte  $_2\checkmark$

*$_2\checkmark$  is contingent on  $_1\checkmark$*

*(if no other answer given) allow  $_{12}\checkmark$  for:*

*'only counts 50 since detector still 'dead' at 0.01 s so only 'sees' odd-numbered photons';*

*use of formula to show  $R_1 = 50$  is neutral*

1

[16]

2.

A

*Its rate of change of momentum is at a minimum.*

[1]

3.

C

10

[1]

4.

B

16N

[1]

5.

(a) Electromagnetic  $\checkmark$

*Reject electrostatic as it is not one of the fundamental forces.*

1

(b) Arrow drawn at X in a direction radially away from the centre of the gold nucleus  $\checkmark$

1

- (c) Answer number 5 or 6 plus one consistent justification ✓  
*First mark must come with at least one justification.*

One more consistent justification ✓

List of justifications:

Cannot be 1, 2, or 3 as these alpha's deflect up. Or must be 5 to 9 as these all alpha's deflect down.

Cannot be 4 as this would backscatter or is scattered at 180°

Cannot be 7, 8 or 9 as the deflection would be too small. Or must be 2, 3, 5, 6 as these have a greater deflection than alpha1.

*The second mark is possible to obtain with two consistent justifications even if the first mark is missed.*

*E.g. if an answer 7 is given then quoting the first two justifications gains a mark.*

2

- (d) (Using of potential energy =  $\frac{Qq}{4\pi\epsilon_0 r}$ )

Substituting the values of the two charges multiplied together into an equation  
 $(2 \times 1.6 \times 10^{-19})(79 \times 1.6 \times 10^{-19})\checkmark_1$

$$PE = \frac{2 \times 79 \times (1.6 \times 10^{-19})^2}{4\pi \times 8.9 \times 10^{-12} \times 5.5 \times 10^{-14}} \text{ or } 6.58 \times 10^{-13} \text{ (J)} \checkmark_2$$

*2 The substitution may be inferred at the next stage of the calculation that uses*

$$KE = \frac{1}{2} mv^2 = PE$$

(loss of KE =  $\frac{1}{2} mv^2 =$  gain in PE)

$$\left( v = \left( \frac{2 \times 6.58 \times 10^{-13}}{6.8 \times 10^{-27}} \right)^{1/2} \right)$$

$$v = 1.4 \times 10^7 \text{ (m s}^{-1}\text{)} \checkmark_3$$

3

- (e) Using by substitution or rearrangement  $R = r_0 A^{1/3}$  ✓

$R_{Ag} = 5.7 \times 10^{-15}$  (m) ✓

$$\left( R_{Ag} = R_{Au} \times \left( \frac{A_{Au}}{A_{Ag}} \right)^{1/3} \right)$$

$$\left( R_{Ag} = 6.98 \times 10^{-15} \times \left( \frac{107}{197} \right)^{1/3} \right)$$

The use of the equation must involve both nuclei.

2

- (f) Nucleons are incompressible / Nucleons have a constant separation / Neutrons and protons have similar masses / Neutrons and protons have similar volumes ✓

A mark can be given for 'nucleons touch' but it must be implied that this is with all 12 neighbours'.

1

[10]

6.

C

to decrease neutron speeds

[1]

7.

A

$2.3 \times 10^8$  W

[1]

8.

- (a) First mark for either both  $\alpha$ 's or both  $\beta^-$ 's arrows shown correctly ie  $\alpha$  arrow moving down 2 and left 2 or  $\beta^-$  arrow moving down 1 and right 1 ✓ (must be sequential)

Second mark for fully correct ✓

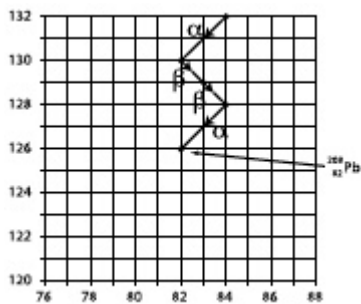

The first mark is independent of the start position.

The question asks for arrows, so a series of positions marked does not gain marks.

One mark can be awarded if all the lines with arrows are included but in wrong direction with lines.

2

(b) **Any 3 marking points from 1 to 5**

<sup>1</sup>Strong nuclear force (SNF) affects nucleons or protons and neutrons. ✓

<sup>2</sup>SNF attraction extends up to 3 fm (allow 1–4 fm) ✓

<sup>3</sup>The SNF is repulsive below about 0.8 fm (allow 0.3 to 1 fm and prevents the nucleus totally collapsing) ✓

<sup>4</sup>Electromagnetic/electrostatic repulsive force (only) acts between protons ✓

<sup>5</sup>EM forces are long range/infinite/acts across whole nucleus/acts on all protons(so increases as proton number increases) ✓

**PLUS one of following that explains the imbalance**

More neutrons are needed to hold nucleus together / add to binding force/increase instability/reduce stability (owtte)

**OR**

Fewer protons are required so as to reduce the repulsion/reduce instability/increase stability (owtte) ✓

*Baryons/hadrons may replace nucleons.*

*If 'strong force' rather than 'strong nuclear force' is used only penalise once.*

*Any wrong statement made in the first group of marking points then this section has a maximum 2 marks out of 3.*

Max 4

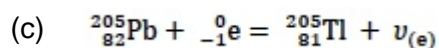

✓ Mark for full equation

*The electron may be represented by  $e^-$  or  $\beta^-$  without the super and subscript.*

*Q may be added to the end of the equation.*

*Encouraged by the following question 'gamma' might appear on the RHS of the equation. Simply ignore gamma.*

1

(d) Orbiting electrons in the atom fall (to fill the positions vacated by inner orbiting electrons releasing their energy as em (gamma) radiation) ✓

The excited nucleus emits gamma radiation (as it de-excites) ✓

*Mark leniently in first mark. Just need to see photons are related to outer electron movement.*

*Allow radiation due to it being above 0 kelvin.*

*For the second mark 'nucleus' must be mentioned but electrons must not.*

2



(e) It is because:

It only emits  $\lambda$ -rays

$\lambda$ -rays are weakly ionising/cause less damage to body than other radiations

$\lambda$ -rays can penetrate/escape from the body

It has low toxicity

Half-life is short enough not to remain in the body for too long after the medical examination

Half-life is long enough to complete the diagnosis

It can be prepared in the hospital/close to the hospital

Any 2 ✓✓

2

[11]

9.

C

$$2.55 \times 10^{-13} \text{ J}$$

[1]

10.

D

[1]

11.

(a) U-235 (absorbs) a neutron with added information ✓<sub>1</sub>

*<sub>1</sub> Possible added information :*

*To become U-236*

*absorbs a slow moving neutron*

*absorbs a thermal neutron*

*If no marks awarded but the first two marking points are made  
without identifying the isotope give one mark*

U-235/6 then divides/splits and gives out more neutrons ✓<sub>2</sub>

U-238 absorbs/scatters neutrons ✓<sub>3</sub>

*<sub>3</sub> If the answer implies that U-238 in any way is involved in fission  
this mark is lost*

3

- (b) Substitution into or manipulation of the equation  $N_t = N_0 e^{-\lambda t}$  to give the ratio  $\frac{N_0}{N_t}$

with  $N_t$  for the present day and  $N_0$  being in the past ✓<sub>1a</sub>

$$\left( \frac{N_0}{N_t} = e^{+\lambda t} = e^{+(1.54 \times 10^{-10} \times 2.0 \times 10^9)} = 1.36 \right)$$

Mass of U-238 (= 1.36 × 0.993) = 1.35 kg (3 sf) ✓<sub>2a</sub>

OR working with half-lives

(Half life = 4.50 × 10<sup>9</sup> year)

Number of half-lives = 4/9 or 0.44 ✓<sub>1b</sub>

$$\left( \frac{N_0}{N_t} = 2^{(4/9)} = 1.36 \right)$$

Mass of U-238 (= 1.36 × 0.993) = 1.35 kg (3 sf) ✓<sub>2b</sub>

*Must be to 3 sig figs*

*Calculation may be in grams*

$${}_{1b} \text{ Half life} = \ln 2 / 1.54 \times 10^{-10}$$

$$= 4.50 \times 10^9 \text{ (year)}$$

$$\text{Number of half-lives} = 2.00 \times 10^9 / 4.50 \times 10^9$$

2

- (c) Ratio  $\left( \frac{N_{235}}{N_{238} + N_{235}} \right) = 3.6\% \text{ to } 3.7\%$

so yes ✓ A valid calculation must be performed to gain the mark eg with an ecf from (b)

$$\left( \frac{N_{235}}{N_{238} + N_{235}} = \frac{52}{1400 + 52} \text{ using (b) data} = \frac{52}{1350 + 52} \right)$$

*Condone using ratio  $\frac{N_{235}}{N_{238}}$*

$$\left( \frac{N_{235}}{N_{238}} = \frac{52}{1400} \text{ using (b) data} = \frac{52}{1350} \right)$$

$$= 3.7\% \text{ to } 3.9\%$$

1

[6]

12.

B

[1]

13.

B

[1]

14.

D

[1]

15.

- (a) To increase the probability/chance of fission (when neutron collides with fissile material/U-235)

Or

To allow the neutron to be absorbed by the fuel/U-235 ✓

*Condone because thermal/slow moving neutrons are needed for fission to take place*

*'fuel' but not 'fuel rod' to be used in the alternative.*

*Reject inaccurate descriptions for example ones that imply the neutrons are undergoing fission.*

1

- (b)  $E_{\text{final}} = (1 - 0.63) E_{\text{incident}}$  or  $E_{\text{final}} = 0.37 E_{\text{incident}}$  ✓<sub>1</sub>

(continuing this idea,  $E_1 = (1 - 0.63) E_0$

$E_2 = (1 - 0.63) E_1$  so  $E_2 = (1 - 0.63)^2 E_0$

and  $E_5 = (1 - 0.63)^5 E_0$

$E_5 = (1 - 0.63)^5 \times 2.0 \times 10^6$  )

$= 1.4 \times 10^4$  eV ✓<sub>2</sub> ( $1.39 \times 10^4$  eV)

*If no marks are scored a single mark can be given:*

*if the final answer that has a power of 10 error possibly by not using the M in the eV.*

OR

*using 0.63 rather than  $(1 - 0.63)$  in the calculation giving the answer*

$2(.0) \times 10^5$  (eV)

✓<sub>2</sub> A correct final answer gains full marks

2

- (c) A link made between the change in kinetic energy or momentum to the masses of the (two) particles involved in the collision. ✓<sub>1</sub>

A consistent argument that results in a statement 'as nucleon number/number of nucleons in the nucleus increases more collisions are required. ✓<sub>2</sub>

✓<sub>1</sub> Ref. to mass is needed.

{Essence of marking point: The mass determines how much KE/momentum is lost}

✓<sub>2</sub> Ref to nucleon number or equivalent needed but mass is not.

{Essence of marking point: If N is high then not much KE is lost so more collisions are needed}

An example of an argument could be:

More (kinetic) energy is lost when the mass of the moderator atom/nucleus is closer to the mass of the neutron

So the number of collisions needed increases with nucleon number

2

(d) Mass difference

$$= (\text{mass}_U + \text{mass}_n) - (\text{mass}_{Xe} + \text{mass}_{Sr} + 4 \text{ mass}_n)$$

$$= (235.044 + 1.0087) - (141.930 + 89.908 + 4 \times 1.0087) \checkmark_1$$

$$= 0.180 \text{ u} \checkmark_2 \text{ \{if no unit present take u as the default unit\}}$$

$$= (0.180 \times 931.5)$$

$$= 168 \text{ (MeV)} \checkmark_3$$

$\checkmark_1$  Mark for word equation or substitution, one neutron may be cancelled from both parts of the subtraction. Condone any simple slip in transferring the numbers.

Also the mark can be awarded for giving or comparing the mass on the LHS with the RHS.

$\checkmark_2$  Only allow correct answer.

$\checkmark_3$  This mark can stand alone for the conversion of any number of u converted to MeV. 2 sig figs is acceptable.

The conversion mark can come from any part of this question not just the final line.

$$\{1 \text{ kg} = 6.02 \times 10^{26}\}$$

A correct answer gains all 3 marks.

- (e) 1. (Small amounts of fossil fuel used) so little greenhouse gas emissions/less global warming/less CO<sub>2</sub>/less climate change. {not no greenhouse gas}
2. (Less fossil fuel used) so cleaner air.
3. Small amounts of fuel consumed to get the same/large amount of power/energy.
4. Nuclear power can be produced continuously{condone use of constant} (whereas renewables are dependent on sunlight/wind etc).
5. Some (but not all) nuclear power stations can adjust their output quickly.
6. Benefit of producing medical isotopes.

✓ ✓ ✓ any three points

*Just one of the examples may be from the following:*

*At present nuclear fuel is obtained from stable allied countries (as opposed to oil/gas).*

*Facilitates nuclear weapon production.*

*(Less fuel used) so less transportation needed.*

*Examples of rejected ideas because they are incomplete or wrong:*

*Produces more energy.*

*There is more uranium than fossil fuel.*

*Damages the environment less.*

*Provides jobs.*

*More efficient than others.*

*Reference to cost.*

*It's a renewable source.*

3

[11]

16.

A

[1]

17.

B

[1]

18.

C

[1]

19.

(a)  $_1\checkmark$  idea of **maximising distance**

use tongs / tweezers / handling tool (when handling source to keep as far away from source as possible)

OR keep at least 2 metres away (if observing)

*award 1 mark for each valid procedure (unless contradicted)*

*do not award more than 1 mark for safety procedure 1 and do not*

*award more than 1 mark for safety procedure 2*

*do **not** credit the same marking point for **different** do not award more than 1 mark for safety procedure 1 procedures*

*for  $_1\checkmark$  treat as neutral: 'keep source at arm's length / far away' / 'use pliers' / don't go close (to the source)*

$_2\checkmark$  idea of **limiting exposure time during** experiment

remove source from lab / room when not in use / after experiment

OR idea of put / replace / keep source in a castle / container when not in use / in the open / after experiment or write

*for  $_2\checkmark$  do not insist on 'lead'*

*treat as neutral: 'use a lead container'*

*treat as neutral: 'limit time of exposure' / 'work as quickly as possible' / 'don't keep source out of box for too long' / 'keep source sealed'*

$_3\checkmark$  is about **shielding** using a named absorber

stand behind a lead absorber / screen (when source is in the open)

*for  $_3\checkmark$  accept aluminium or steel for lead; use of lead apron*

$_4\checkmark$  is safe use of source when removed from castle

never point (open end of) the source at anyone / at yourself

OR do not look directly at / look into the source

*for  $_4\checkmark$  accept 'avoid eyes'*

*treat as neutral: 'avoid direct contact' / 'don't touch source' / 'always point source at ground'*

$_5\checkmark$  is about **good practice**

read local rules (about the use of radioactive sources) /

OR read / post warning / notice on the door

for  $_5\checkmark$  accept 'report any damage to a source'

treat as neutral: 'use safety screen' / 'don't stand in front' / 'don't ingest / swallow' / 'wash hands after use' / 'wear safety glasses / goggles / gloves / lab coats' / 'use film badge'

no credit for procedures that are the responsibility of the teacher / radiation protection adviser, eg 'obtained signed consent form'

MAX 2

(b) 5  $\checkmark$

correct answer only

1

(c) A

OR  $^{222}_{86}\text{Rn}$  / radon 222 /  $\text{Rn}_{222}\checkmark$

B

OR  $^{218}_{84}\text{Po}$  / polonium 218 /  $\text{Po}_{218}\checkmark$

I

OR  $^{210}_{82}\text{Pb}$  / lead 210 /  $\text{Pb}_{210}\checkmark$

if candidates have provided more than 3 responses, each extra error / contradiction negates one correct response; if there are 3 or more errors / contradictions, award no marks

answers may be given **in any order**

accept unnamed isotope with correct A, Z eg  $^{222}_{86}\text{X}$

eg while the suggestion that A, B and I are correct earns 3 the suggestion that A, B, I and J are correct earns 3 – 1 = 2

3

(d) suitable procedures to eliminate systematic error are:

remove (all radioactive) source(s) (from the room)

OR

measure  $A_b$  before the source is present / in another room

OR

put source in (lead) castle / (lead) container / behind a (lead) absorber  $_1\checkmark$

zero / reset the counter AND/OR stopwatch (before use)

do not insist on references to systematic or random error but give no credit for explicit talk-out eg 'use a long integration time to eliminate systematic error'

for  $_1\checkmark$  treat as neutral: 'measure  $A_b$  with no source near' / 'check source is shielded / far away / out of range / sealed' / 'in another area' / 'point detector away from the source (or vice-versa)' / 'don't point source at counter' / 'put detector behind source'

OR

check the counter AND/OR stopwatch has no zero error  $_{2}\checkmark$

*for  $_{2}\checkmark$  treat as neutral: 'zero / reset the equipment (before use)' / 'zero the detector'*

measure  $A_b$  on same day as experiment is carried out  $_{3}\checkmark$

*for  $_{3}\checkmark$  treat as neutral: 'measure  $A_b$  after experiment to double-check'*

measure  $A_b$  in same room / location / area as that where experiment is to be carried out  $_{4}\checkmark$

*for  $_{4}\checkmark$  treat as neutral: / 'keep detector in the same position' / 'measure  $A_b$  in different positions'*

suitable procedure to reduce percentage uncertainty in  $A_b$  is:

use long(er) (integration) time / prolonged time

OR

(total of) at least 100 s  $_{5}\checkmark$

*for  $_{5}\checkmark$  accept idea of a suggested total time, taking account of repeats, exceeding 100 s (eg 10 repeated 10 s counts and 1 single 100 s single count amount to the same thing) treat as neutral: 'repeat and average' ignore anomalous results' / 'use room with high background count / record large reading' / 'use more than one detector'*

MAX 3



(e) use of 5.5 MeV shown by **working** on **Figure 4** <sub>1</sub>✓

minimum thickness MAX 3sf that rounds to 12 mm <sub>2</sub>✓<sub>3</sub>✓

OR

minimum thickness MAX 3sf that rounds to 11 mm / MAX 3sf that rounds to 13 mm <sub>23</sub>✓

*for <sub>1</sub>✓ use of 5.5 MeV can be inferred from **Figure 4** as a (horizontal) **line**, a **mark** on the vertical axis or a **mark** on the curve / intersection between curve and a vertical line, **above 5 MeV and below 6 MeV**;*

*a single line / mark between 5 and 6 MeV with no subsequent working can score <sub>1</sub>✓*

*any line does not have to be ruled or perfectly parallel to the grid line;*

*allow a cross or a small blob as the mark on the curve;*

*do not insist on seeing a vertical line*

*if more than one line is drawn / mark is made then mark as per scheme if a clear decision has been made about which read-off has been used to provide the result for the **thickness**;*

*allow only one **thickness** given as final answer*

*<sub>2</sub>✓ <sub>3</sub>✓ OR <sub>23</sub>✓ can be earned without any working on the grid / other intermediate working*

OR

use of 7.8 MeV shown by working on **Figure 4** AND minimum thickness is 16, 17 or 18 mm <sub>123</sub>✓

*for <sub>123</sub>✓ use of of 7.8 MeV can be inferred from **Figure 4** as a line, mark on axis / curve etc above 7 MeV and below 8 MeV; accept MAX 3 sf result that rounds to 16, 17 or 18 mm*

(f)  $d = \sqrt{k} \times \frac{1}{\sqrt{A}} - e$  OR  $d = \sqrt{k} \times \sqrt{\frac{1}{A}} - e$  OR  $d = \sqrt{\frac{k}{A}} - e$  seen  $_1\checkmark$

**states**  $\sqrt{k}$  = gradient OR  $k$  = gradient<sup>2</sup>  $_2\checkmark$

gradient from  $\Delta d$  divided by  $\frac{1}{\sqrt{A}}$  with  $\Delta \frac{1}{\sqrt{A}} \geq 0.5$   $_3\checkmark$

$k$  minimum 2 sf in range  $1.7(0) \times 10^5$  to  $1.9(5) \times 10^5$   $_4\checkmark$

unit for  $k$  =  $\text{mm}^2 \text{Bq}$  or  $\text{mm}^2 \text{s}^{-1}$   $_5\checkmark$

for **statement** that  $k$  = gradient mark as follows:

for  $d = k \times \frac{1}{\sqrt{A}} - e$  **AND**  $k$  = gradient  $_12\checkmark = 1$  MAX;

award  $_3\checkmark$  as above

$45\checkmark = 1$ MAX ecf for the following:

$k$  in range 410 to 450 or 2 sf 4.1 to  $4.5 \times 10^2 \text{mm Bq}^{0.5}$  or  $\text{mm s}^{-0.5}$

OR

$k$  in range 0.41(0) to 0.45(0)  $\text{m Bq}^{0.5}$  or  $\text{m s}^{-0.5}$

OR

$k$  in range 41.(0) to 45.(0)  $\text{cm Bq}^{0.5}$  or  $\text{cm s}^{-0.5}$

for  $_1\checkmark$   $d$  must be the subject;

allow obvious slips, eg  $D$  for  $d$

for  $_2\checkmark$  allow  $\sqrt{k} = m$  if  $y = mx + c$  is quoted so inference that  $\sqrt{k} =$  gradient is clear; this mark is for **explaining** the step and **not** for performing the calculation

for  $_3\checkmark$  the mark is for the process, not the result; evidence of acceptable steps on grid with plausible result are enough; no credit if false origin missed allow working subsumed into calculation of  $k$

for  $_4\checkmark$  gradient based on  $d$  in mm (expected = 433 mm  $\text{Bq}^{0.5}$ ) POT  $10^5$  required

for  $_5\checkmark$  the unit given for  $k$  must be consistent with the POT of the result for  $k / \text{gradient}^2$

order not important  $\text{Bq mm}^2$  is acceptable; do not accept incorrect symbol, eg  $\text{bq}$  for  $\text{Bq}$

otherwise:

if for  $_4\checkmark$  gradient based on  $d$  in m (expected  $\approx 0.43 \text{ m Bq}^{0.5}$ )  $k$  in range 0.17(0) to 0.19(5)

then for  $_5\checkmark$   $\text{m}^2 \text{ Bq}$  or  $\text{m}^2 \text{ s}^{-1}$

if for  $_4\checkmark$  gradient based on  $d$  in cm (expected  $\approx 43 \text{ cm Bq}^{0.5}$ )  $k$  in range  $1.7(0) \times 10^3$  to  $1.9(5) \times 10^3$

then for  $_5\checkmark$   $\text{cm}^2 \text{ Bq}$  or  $\text{cm}^2 \text{ s}^{-1}$

2  
1  
2

- (g) second mark ( $_{2}\checkmark$ ) **is contingent on** award of first ( $_{1}\checkmark$ )

an unsupported answer or an answer obtained by scale drawing or by extrapolation off the grid score zero

attempts to find  $e$  by calculation by any valid method using gradient or  $k$  with all data **correctly** substituted in **their** expression;

allow use of  $y$  for  $d$ ,  $x$  for  $\frac{1}{\sqrt{A}}$ ,  $m$  for  $\sqrt{k}$  and  $c$  for  $e$ ;

attempts to solve for  $e$   $_{1}\checkmark$

for  $_{1}\checkmark$  use of  $y = mx + c$  with recognisable data **correctly** substituted, eg

$e = \text{their gradient} \times \frac{1}{\sqrt{A}} - d$  with substitution of their gradient and

values of values of  $d$  and  $\frac{1}{\sqrt{A}}$  from a point on the line from **Figure 6**

OR

$e = \sqrt{k} \times \frac{1}{\sqrt{A}} - d$  with substitution of their  $k$  etc

OR

$(-e) = \text{gradient} \times \text{horizontal intercept}$ , with substitution of their gradient and horizontal intercept

ignore POT errors in their gradient / their  $k$ ;

allow mixed units and read-off errors of 1 small square

1

$\geq 2$  sf result in range  $\geq 28(.0)$  and  $\leq 32(.0)$  (mm)  $_{2}\checkmark$

for  $_{2}\checkmark$  answer in range only (no ecf from 01.6) allow negative answer

1

[19]

20.

A

[1]

21.

C

[1]

22.

- (a)
- $\gamma$
- radiation because it is very / the most penetrating

**OR** $\gamma$  radiation because it is penetrating enough to irradiate all sides of the instruments**OR** $\gamma$  radiation is penetrating so instruments can be sterilised without removing the packaging

✓ OWTTE

*The quoted radiation must be gamma only and not a mixture**It is not sufficient to just state 'gamma'. The mark is based on the reason for the choice*

1

- (b) To become radioactive the nucleus has to be affected which (ionising) radiation does not do

**OR**(Ionising) radiation only affects the outer electrons and not the nucleus**OR**

The energy of the radiation is insufficient to induce radioactivity. (For this mark high energy is not the same as highly ionizing)

**OR**

(Ionising) radiation does not affect the nucleus ✓ owtte

1

- (c) (Conclusion using the inverse square law
- $I = k/d^2$
- )

Make the point that  $I \times d^2$  should be constant if the inverse square law is operating ✓ owtteShow calculations using data from 3 rows

The column may be completed in the following ways ✓

Corrected count rate count s <sup>-1</sup>	$I \times d^2$ Using $I$ as count rate		$I \times d^2$ Using $I_{\infty}$ count in 1.0 minute
150	6.00	Or	361
23.3	5.83		349
4.03	4.03		242

Accept 2 sig figs and 1 sig fig in the case of the 4 and 6 in the second column shown here.

The mark is mainly based on the technique used.

The written answer must be enough to indicate a conclusion.

This mark can be gained even if there is a slip in the table.

The conclusion mark can be gained even if the second mark is lost because only two data points are taken.

Look out for different approaches. E.g. use the CCR at one distance to predict the CCR at other distances if the inverse function is followed. E.g. CCR might be in order 9013, 1440 and 360.

2

(d) **Mark given for any of these ideas (max 2)**

The random nature of the radiation count (although small in this case)

Dead-time in the G-M detector

$d$  is not the real distance between source and detector **OR** source is not a point source

The source may not be a pure gamma emitter

(Gamma and beta is acceptable but not gamma and alpha together)

A reference to short half-life provided that an explanation of how this has an effect on separate measurements eg activity changes during the measurements

Assumes no absorption between source and detector(although small in this case)

✓✓

*No credit for unexplained bland statements such as 'because of systematic errors' **OR** 'more data needs to be taken to be certain' etc.*

*Note: reference to background count does not gain a mark because the corrected count-rate is supplied in the question.*

2

[6]

23.

C

[1]

24.

D

[1]

25.

(a) 2.0 cm ✓ (allow 1.96 to 2.00 cm)

(Answer alone gains mark and ignore number of sig. figs)

*(The depth halves in 19s. With the graph being exponential the depth will halve every 19s.  $57/19 = 3$  so the halving occurs 3 times.  $16\text{ cm} \rightarrow 8\text{ cm} \rightarrow 4\text{ cm} \rightarrow 2\text{ cm}$ )*

1

- (b) Use more water/greater depth/greater volume (in the existing cylinder)

(This should give the same half-life) ✓

*Assume the word water is present in the answer if there is no reference to it. Eg 'greater depth' is taken as 'greater depth of water'.*

1

- (c) Closing the tap more

**OR**

Using a more viscous fluid (density is not the same as viscosity)

**OR**

Using a wider cylinder

**OR**

Use a smaller diameter capillary/narrow tube ✓

*To decrease the decay constant the depth decrease rate should be reduced ie the cylinder should take longer to empty).*

*Changes to the tube need to be specific.*

*Also tube needs to be identified.*

1

- (d) (Using  $T_{1/2} = \ln 2 / \lambda = 0.693 / 1.42 \times 10^{-11}$ )

$$T_{1/2} = 4.9(4.88) \times 10^{10} \text{ (year) } \checkmark$$

1

- (e) (Use of  $N = N_0 e^{-\lambda t}$  mass is proportional to number so

$$m = m_0 e^{-\lambda t}$$

$$m_0 = m e^{+\lambda t}$$

$$\lambda t = 1.42 \times 10^{-11} \times 4.47 \times 10^9 \text{ or } 0.0635 \checkmark$$

$$(m_0 = 1.23 \times 10^{-3} e^{1.42 \times 10^{-11} \times 4.47 \times 10^9})$$

$$m_0 = 1.31 \times 10^{-3} \text{ (g) } \checkmark \text{ (allow and look out for unit being modified to mg)}$$

Mark for 3 sig figs but must be attached to a final answer for mass with some attempt at a relevant exponential calculation ✓

*May calculate  $N = 8.51(2) \times 10^{18}$  and  $N_0 9.07 \times 10^{18}$  but marks will be the same.*

3

(f)  $(N = \text{mass}/87u = 1.23 \times 10^{-6} / (87 \times 1.661 \times 10^{-27}))$

$$N = 8.5(1) \times 10^{18} \checkmark$$

(This does not have to be calculated out for the mark)

$$(\lambda = 1.42 \times 10^{-11} / (365 \times 24 \times 60 \times 60) = 4.50 \times 10^{-19})$$

$$(A = \lambda N = 4.50 \times 10^{-19} \times 8.51 \times 10^{18})$$

$$A = 3.8(4) \checkmark \text{ (this calculation must use in seconds)}$$

Bq, B/becquerel, counts  $\text{s}^{-1}$  or  $\text{s}^{-1} \checkmark$

*In first mark is obtainable from calculating number of moles and then multiplying by Avogadro's number.*

$$\{n = 1.23 \times 10^{-6} / 87 = 1.41 \times 10^{-5}$$

$$N = 1.41 \times 10^{-5} \times 6.02 \times 10^{23}\}$$

*A power of 10 error will count as an AE and will allow an error carried forward.*

*Answer must follow working showing correct process as correct answer can come from incorrect working.*

3

[10]

26.

C

[1]

27.

D

[1]

28.

- (a) (moderator) - the neutron undergoes an elastic collision / bounces off with less speed / kinetic energy  $\checkmark$  (Any reference to absorption loses the mark)

*Must have the idea that the neutron slow because of collisions*

1

- (b) (control rod) – the neutron is absorbed  $\checkmark$

*'stopped' will not get the mark.*

*If alternatives are given all must be correct to gain mark.*

1

- (c) the neutron is absorbed/U-236 is formed  $\checkmark$   
 (causing) the nucleus (of fuel / uranium) to split into (two smaller) daughter nuclei / nuclei / fragments  $\checkmark$   
 releasing (several fast-moving) neutrons  $\checkmark$

*1<sup>st</sup> mark can use words like absorbed / takes in /*

*2<sup>nd</sup> mark: alternative words for nuclei are **not** acceptable (eg daughter products)*

*3<sup>rd</sup> mark 'neutrons' must be plural.*



(d)

<b>Descriptor</b>	<b>(Bullet point headings are detailed at the bottom end of the table)</b>	<b>Mark</b>
<p>High Level – Good to Excellent</p> <p>All three bullet points must be addressed. The source must be identified and two stages in the treatment sequence must be given. Finally three problems encountered in the treatment of waste and how the problems are overcome should be stated. (Note discussion of a problem will often cover a stage of the treatment).</p> <p><i>The information presented as a whole should be well organised using appropriate specialist vocabulary. There should only be one or two spelling or grammatical errors for this mark.</i></p>	<p>6 marks = At least 6 points made coming from all three of the bullet point headings.</p> <p>(note some written points may count as answers to bullet point headings 2 and 3)</p> <p>5 marks = 5 points made coming from all three of the bullet point headings.</p> <p>To be in this top band communication skills must be good and the ideas easy to follow.</p>	5-6
<p>Intermediate Level – Modest to Adequate</p> <p>All three bullet points must be addressed. The source must be identified as well as a stage in the treatment along with a problem encountered in the treatment of waste and how it is dealt with. One additional piece of information must be made from any of the bullet points listed below to be at the top of this band.</p> <p><i>The grammar and spelling may have a few shortcomings but the ideas must be clear.</i></p>	<p>4 marks = 4 points made coming from at least 2 bullet point headings.</p> <p>3 marks = 3 points made coming from at least 2 bullet point headings.</p> <p>To be in this moderate band communication skills must be good enough to understand the ideas easily even if the order is a little unclear.</p>	3-4
<p>Low Level – Poor to Limited</p> <p>To be at the top of this band two bullet points must be addressed which must include a problem encountered in the treatment of waste and how it is dealt with.</p> <p>A single mark is awarded if any of the information given in the bullet points listed below is given.</p> <p><i>There may be many grammatical and spelling errors and the information may be poorly organised.</i></p>	<p>2 marks =</p> <p>Two points made from any bullet point heading.</p> <p>1 mark = any point made coming from any bullet point heading. Or the script as a whole shows some basic understanding of the issues.</p>	1-2
<p><b>The description expected in a competent answer should include:</b></p> <p><b>1<sup>st</sup> bullet point</b></p> <p>The (highly radioactive/ most dangerous)</p>		

waste are the fission fragments from the fission of uranium-235 or from (spent) fuel rods.

### **2<sup>nd</sup> bullet point**

The waste is initially placed in cooling ponds/water (close to the reactor for a number of years)

plutonium/uranium is separated to be recycled

high level waste is vitrified/made solid into (pyrex) glass

then placed in (stainless) steel/lead/concrete cylinders/containers/bunkers

to be stored **deep** underground (simply stating buried/underground is not enough)

### **3<sup>rd</sup> bullet point**

(the problem and its solution must both be given, some examples are given below)

the waste is (initially) is very hot/generates heat so has to be placed in water/cooling ponds (to remove the heat)

the waste (initially) is highly radioactive and needs to be screened in water/cooling ponds (to absorb the radiation)

the waste (initially) is highly radioactive and needs to be remotely handled (to avoid human contact with the waste).

In liquid form the (high level) waste may leak hence the need to vitrify (and barrel in steel)

The waste will be radioactive for hundreds/thousands of years so storage needs to be stable in a container hence the need to vitrify (and barrel in stainless steel)

The waste will be radioactive for hundreds/thousands of years so long term storage needs to be in geologically stable areas (deep underground).

Transporting waste presents a potential danger to the public so waste is transported enclosed in impact/crash resistant/extra thick and strong casings Or processed onsite or nearby.

29. B

[1]

30. B

[1]

31.

(a) (using mass defect =  $\Delta m = Z m_p + N m_n - M_{Co}$ )

$$\Delta m = 27 \times 1.00728 + 32 \times 1.00867 - 58.93320 \text{ (u)} \checkmark$$

$$\Delta m = 0.5408 \text{ (u)} \checkmark$$

Binding Energy =  $0.5408 \times 931.5 = 503.8 \text{ (MeV)} \checkmark$  (CE this mark stands alone for the correct energy conversion even if more circular routes are followed.

*Look at use of first equation and if electrons are used or mass of proton and neutron confused score = 0.*

*If subtraction is the wrong way round lose 1 mark.*

*Data may come from rest mass eg  $m_n = 939.551 \text{ MeV}$  or  $1.675 \times 10^{-27} \text{ kg}$  or  $1.00867 \text{ u}$ .*

*So if kg route used  $\Delta m = 8.83 \times 10^{-28} \text{ kg}$   $BE = 7.95 \times 10^{-28} \text{ J}$  and  $497 \text{ MeV}$ .*

*Conversion mark (2nd) may come from a wrong value worked through. 0.47(5)*

3

(b)  $(2.52 - 1.76) \times 10^{-13} = 7.6 \times 10^{-14} \text{ J} \checkmark$ 

$$7.6 \times 10^{-14} / 1.60 \times 10^{-13} = 0.47 \text{ or } 0.48 \text{ MeV} \checkmark (0.475 \text{ MeV})$$

*Correct answer scores both marks.*

2

(c) 6 (specific wavelengths)



1

(d) (longest wavelength = lowest frequency = smallest energy)

$$(2.29 \times 10^{-13} - 2.06 \times 10^{-13}) = 2.3 \times 10^{-14} \text{ (J)} \checkmark$$

$$\lambda (= h c / E) = 6.63 \times 10^{-34} \times 3.00 \times 10^8 / 2.3 \times 10^{-14} \checkmark$$

$$\lambda = 8.6 - 8.7 \times 10^{-12} \text{ (m)} \checkmark (8.6478 \times 10^{-12} \text{ m})$$

*Allow a CE in the second mark only if the energy corresponds to an energy gap including those to the ground state.*

*The allowed energy gaps for CE are:*

$$2.29, 2.06, 1.76, 0.53, 0.30 \text{ all } \times 10^{-13}$$

*Note substitution rather than calculation gains mark.*

*The final mark must be as shown here and not from a CE above.*

3

[9]

32. A

[1]

**33.** D

[1]

**34.** C

[1]