

Q1. The figure below shows a balloon filled with helium gas.

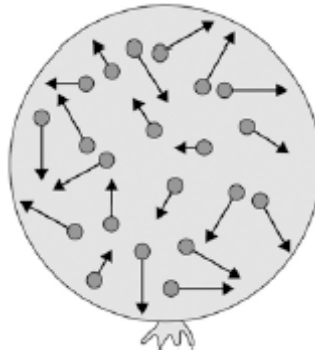

(a) Describe the movement of the particles of helium gas inside the balloon.

.....
.....
.....
.....

(2)

(b) What name is given to the total kinetic energy and potential energy of all the particles of helium gas in the balloon?

Tick **one** box.

External energy

Internal energy

Movement energy

(1)

(c) Write down the equation which links density, mass and volume.

.....

(1)

(d) The helium in the balloon has a mass of 0.00254 kg.

The balloon has a volume of 0.0141 m^3 .

Calculate the density of helium. Choose the correct unit from the box.

m^3 / kg	kg / m^3	kg m^3
--------------------------	--------------------------	-----------------

.....

.....

.....

.....

Density = Unit

(3)
(Total 7 marks)

Q2. The diagram shows two thermometers. The bulb of each thermometer is covered with a piece of wet cotton wool. One of the thermometers is placed in the draught from a fan.

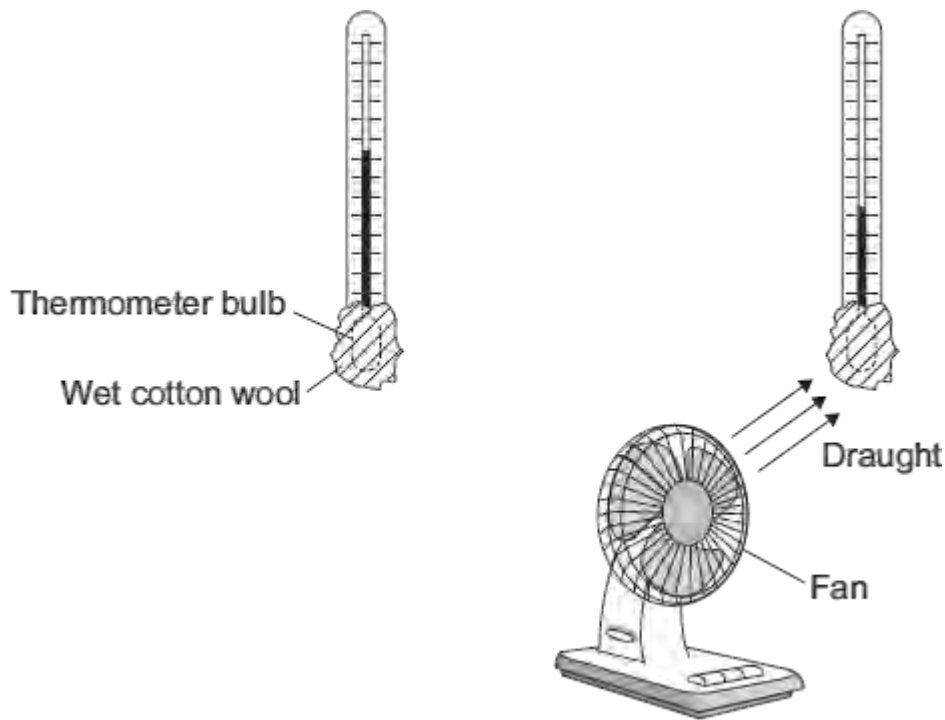

The graph shows how the temperature of each thermometer changes with time.

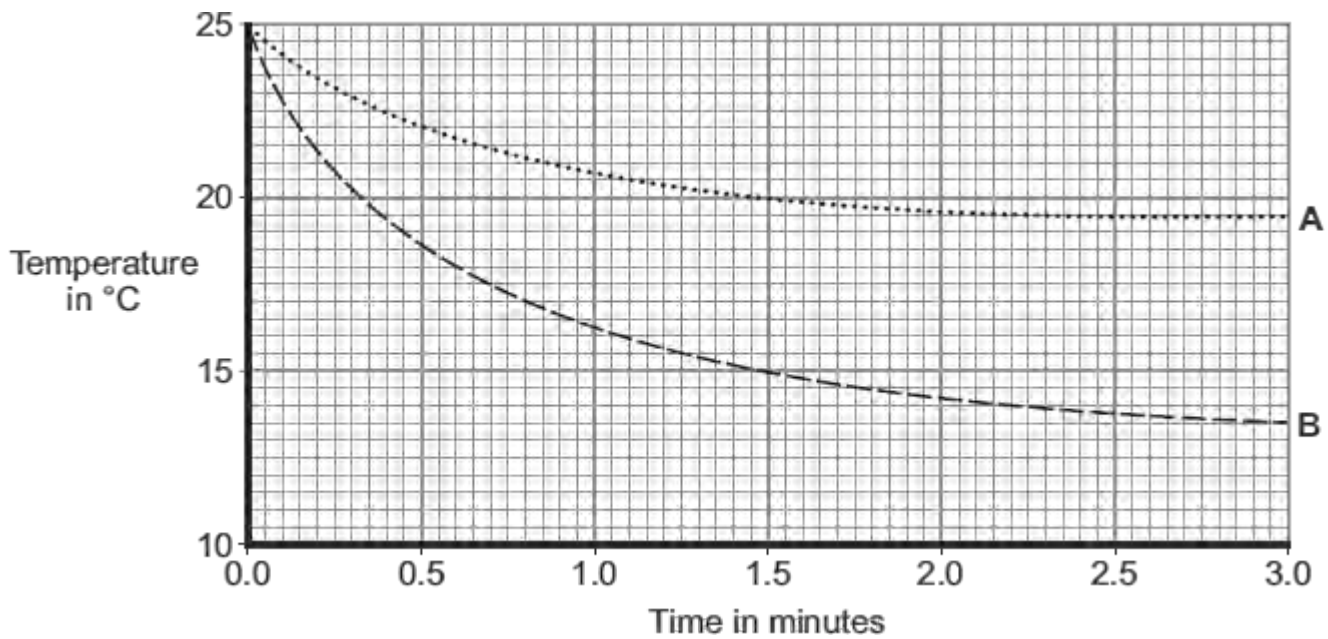

- (a) Which of the graph lines, **A** or **B**, shows the temperature of the thermometer placed in the draught?

Write the correct answer in the box.

Explain, in terms of evaporation, the reason for your answer.

.....

.....

.....

.....

.....

.....

(3)

- (b) A wet towel spread out and hung outside on a day without wind dries faster than an identical wet towel left rolled up in a plastic bag.

Explain why.

.....

.....

.....

.....

(2)

(Total 5 marks)

Q3.Heat exchangers are devices used to transfer heat from one place to another.

The diagram shows a pipe being used as a simple heat exchanger by a student in an investigation.

Heat is transferred from the hot water inside the pipe to the cold water outside the pipe.

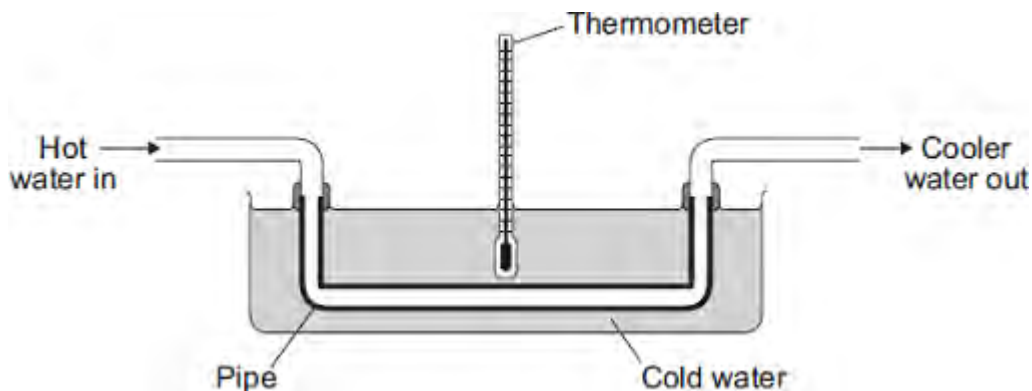

- (a) Complete the following sentence by drawing a ring around the correct word in the box.

Heat is transferred from the hot water inside the pipe

to the cold water outside the pipe by

conduction
convection.
radiation.

(1)

- (b) The student wanted to find out if the efficiency of a heat exchanger depends on the material used to make the pipe. The student tested three different materials. For each material, the rate of flow of hot water through the pipe was kept the same.

The student's results are recorded in the table.

Material	Temperature of the cold water at the start in °C	Temperature of the cold water after 10 minutes in °C
Copper	20	36
Glass	20	23
Plastic	20	21

- (i) The rate of flow of hot water through the pipe was one of the control variables in the investigation.

Give **one** other control variable in the investigation.

.....

(1)

- (ii) Which **one** of the three materials made the best heat exchanger?

.....

Give a reason for your answer.

.....

.....

.....

(2)

- (c) The student finds a picture of a heat exchanger used in an industrial laundry. The heat exchanger uses hot, dirty water to heat cold, clean water.

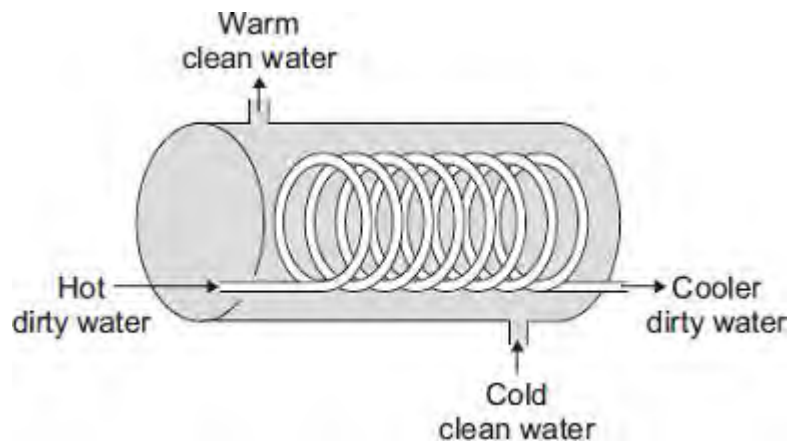

This heat exchanger transfers heat faster than the heat exchanger the student used in the investigation.

Explain why.

.....

.....

.....

.....
(2)
(Total 6 marks)

Q4.(a) *In this question you will be assessed on using good English, organising information clearly and using specialist terms where appropriate.*

The diagram shows the structure of a vacuum flask.

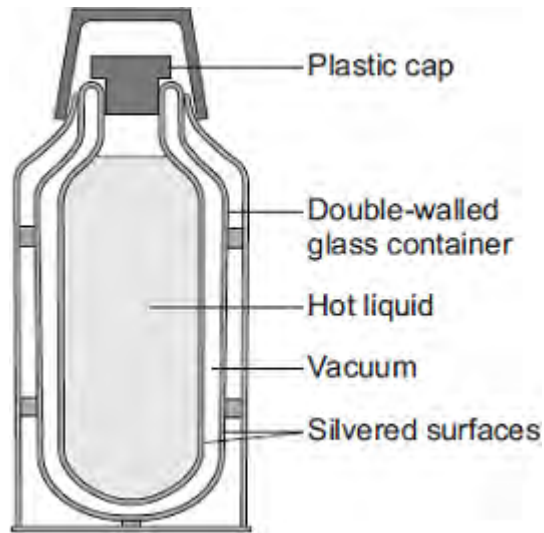

A vacuum flask is designed to reduce the rate of energy transfer by heating processes.

Describe how the design of a vacuum flask keeps the liquid inside hot.

.....

.....

.....

.....

.....

.....

.....

.....

.....

.....

.....

(6)

(b) Arctic foxes live in a very cold environment.



© Purestock/Thinkstock

Arctic foxes have small ears.

How does the size of the ears help to keep the fox warm in a cold environment?

.....

.....

.....

.....

.....

(2)
(Total 8 marks)

Q5. The picture shows a person taking a hot shower.



(a) When a person uses the shower the mirror gets misty.

Why?

.....

.....

.....

.....

.....

.....

.....

.....

.....

(3)

(b) The homeowner installs an electrically heated mirror into the shower room.

When a person has a shower, the heated mirror does **not** become misty but stays clear.

Why does the mirror stay clear?

.....

.....

.....

.....

.....

(2)

(Total 5 marks)

Q6.The diagram shows three cups **A**, **B** and **C**.

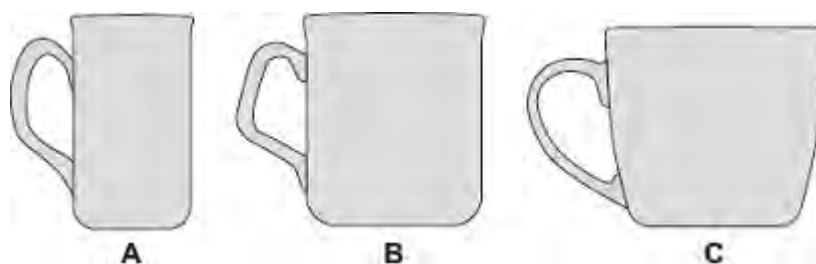

Energy is transferred from hot water in the cups to the surroundings.

(a) Use the correct answer from the box to complete each sentence.

condensation	conduction	convection
---------------------	-------------------	-------------------

Energy is transferred through the walls of the cup by

In the air around the cup, energy is transferred by

(2)

(b) Some students investigated how the rate of cooling of water in a cup depends on the surface area of the water in contact with the air.

They used cups **A**, **B** and **C**. They poured the same volume of hot water into each cup and recorded the temperature of the water at regular time intervals.

The results are shown on the graph.

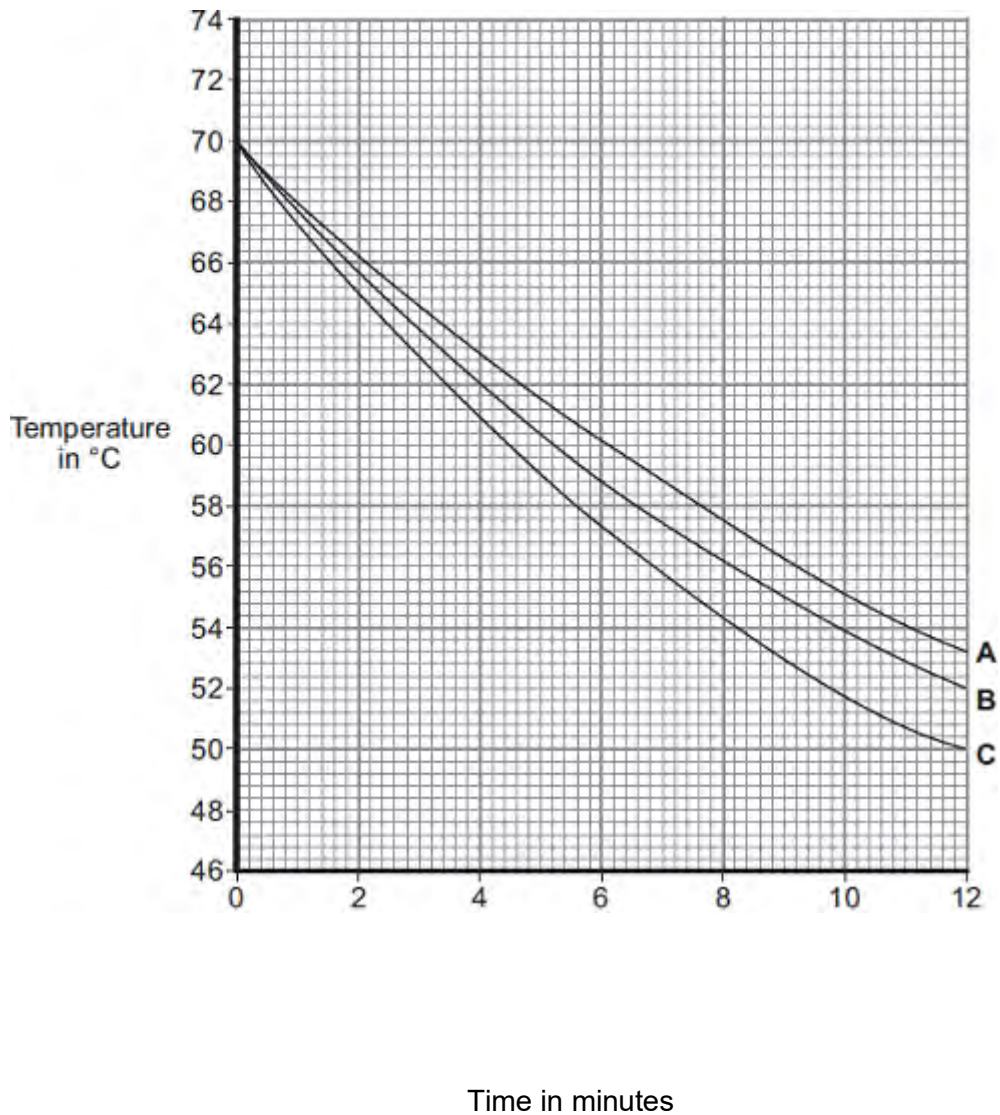

(i) What was the starting temperature of the water for each cup?

Starting temperature = °C

(1)

(ii) Calculate the temperature fall of the water in cup **B** in the first 9 minutes.

.....

Temperature fall = °C

(2)

(iii) Which cup, **A**, **B** or **C**, has the greatest rate of cooling?



Using the graph, give a reason for your answer.

.....
.....

(2)

(iv) The investigation was repeated using the bowl shown in the diagram.

The same starting temperature and volume of water were used.



Draw on the graph in part (b) another line to show the expected result.

(1)

(v) After 4 hours, the temperature of the water in each of the cups and the bowl was 20°C.

Suggest why the temperature does **not** fall below 20°C.

.....

(1)

(c) (i) The mass of water in each cup is 200 g.

Calculate the energy, in joules, transferred from the water in a cup when the temperature of the water falls by 8°C.

Specific heat capacity of water = 4200 J / kg°C.

.....
.....
.....

Energy transferred = J

(3)

(ii) Explain, in terms of particles, how evaporation causes the cooling of water.

.....
.....
.....
.....
.....
.....
.....
.....
.....

(4)

(Total 16 marks)

Q7. In this question you will be assessed on using good English, organising information clearly and using specialist terms where appropriate.

The information in the box is about the properties of solids and gases.

<p>Solids:</p> <ul style="list-style-type: none">• have a fixed shape• are difficult to compress (to squash). <p>Gases:</p> <ul style="list-style-type: none">• will spread and fill the entire container• are easy to compress (to squash).
--

Use your knowledge of kinetic theory to explain the information given in the box.

You should consider:

- the spacing between the particles
- the movement of individual particles
- the forces between the particles.

.....

.....

.....

.....

.....

.....

.....

.....

.....

.....

.....

.....

.....

.....

.....

.....

.....

.....

.....

.....

.....

.....

.....

Extra space

.....

.....

.....

.....

.....

.....

.....

.....

.....

.....

.....

.....

.....

.....

.....

.....

.....

.....

.....

.....

(Total 6 marks)

Q8.Figure 1 shows one way that biscuit manufacturers cook large quantities of biscuits.

The uncooked biscuits are placed on a moving metal grid.

The biscuits pass between two hot electrical heating elements inside an oven.

The biscuits turn brown as they cook.

Figure 1

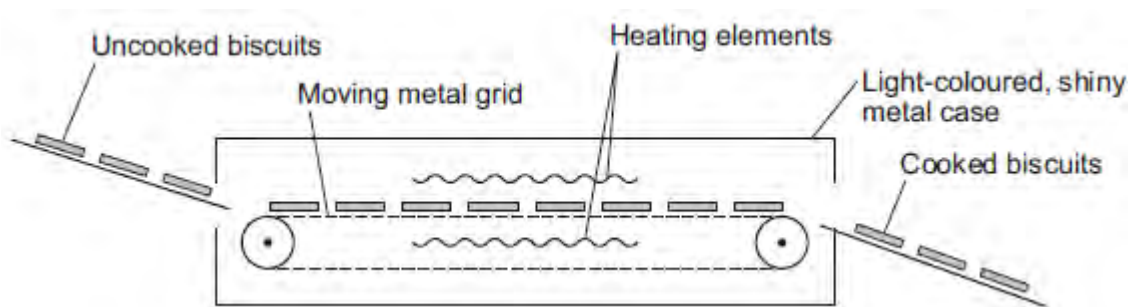

The oven has two control knobs, as shown in **Figure 2**.

Figure 2

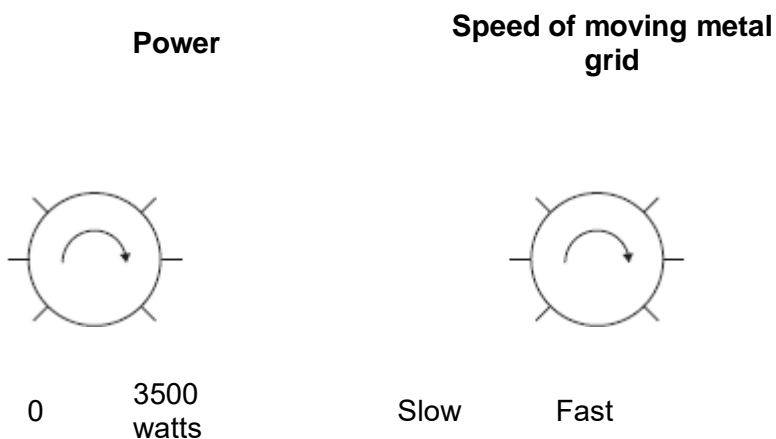

(a) Which type of electromagnetic radiation makes the biscuits turn brown?

.....

(1)

(b) Suggest **two** ways of cooking the biscuits in this oven, to make them turn browner.

1

.....

2

(2)

(c) The inside and outside surfaces of the oven are light-coloured and shiny.

Explain why.

.....
.....
.....
.....
.....
.....

(3)

(Total 6 marks)