

# A LEVEL PHYSICS

## WORKED SOLUTIONS

### 5.1. Current Electricity MCQ



1. In the circuit shown, the cell has an emf of 12 V and an internal resistance which is not negligible.

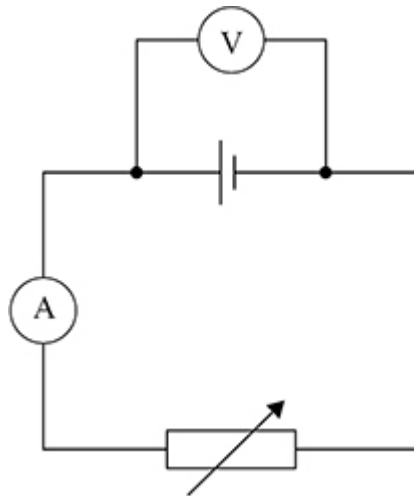

0

When the resistance of the variable resistor is 10 Ω the voltmeter reads 10 V and the ammeter reads 1.0 A.

The resistance of the variable resistor is changed to 5 Ω.

$$V = \mathcal{E} - Ir$$

What is the new reading on the ammeter?

A 1.4 A

B 1.7 A

C 2.0 A

D 2.4 A

$$r = \frac{\mathcal{E} - V}{I} = \frac{12 - 10}{1.0} = 2.0 \Omega$$

$$I = \frac{\mathcal{E}}{R + r} = \frac{12}{5 + 2} = 1.71 \text{ A}$$

(Total 1 mark)

2. The diagram shows the currents in a set of wires.

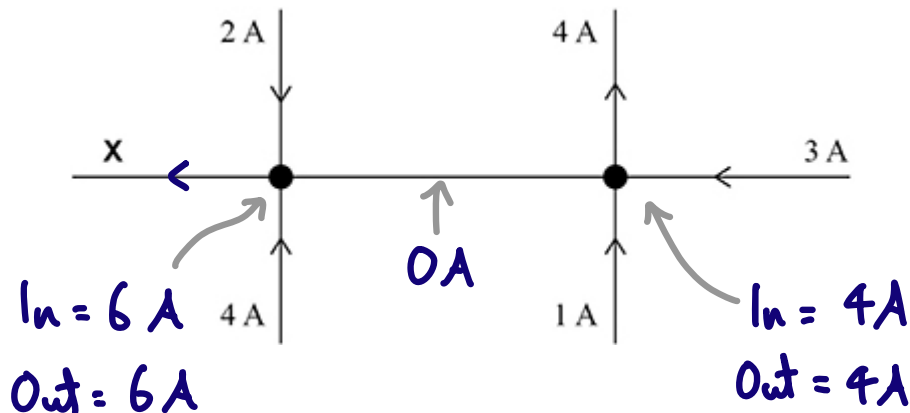

What is the magnitude of the current at **X**?

A zero

B 2 A

C 3 A

D 6 A

(Total 1 mark)

3.

Resistors of resistance  $R$ ,  $R$  and  $3R$  are connected as shown.

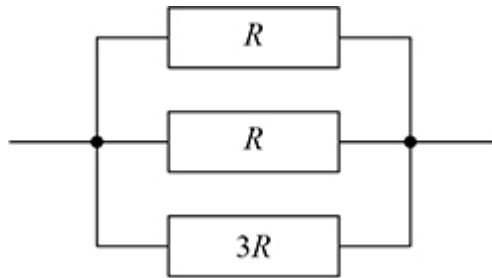

What is the resistance of the arrangement?

A  $\frac{3R}{7}$

B  $\frac{7R}{3}$

C  $\frac{5R}{6}$

D  $\frac{6R}{5}$

$$\frac{1}{R_T} = \frac{1}{R} + \frac{1}{R} + \frac{1}{3R}$$

$$\frac{1}{R_T} = \frac{3}{3R} + \frac{3}{3R} + \frac{1}{3R}$$

$$\frac{1}{R_T} = \frac{7}{3R}$$

$$R_T = \frac{3R}{7}$$

(Total 1 mark)

4. The graph shows the current–voltage ( $I$ – $V$ ) characteristics for two components.

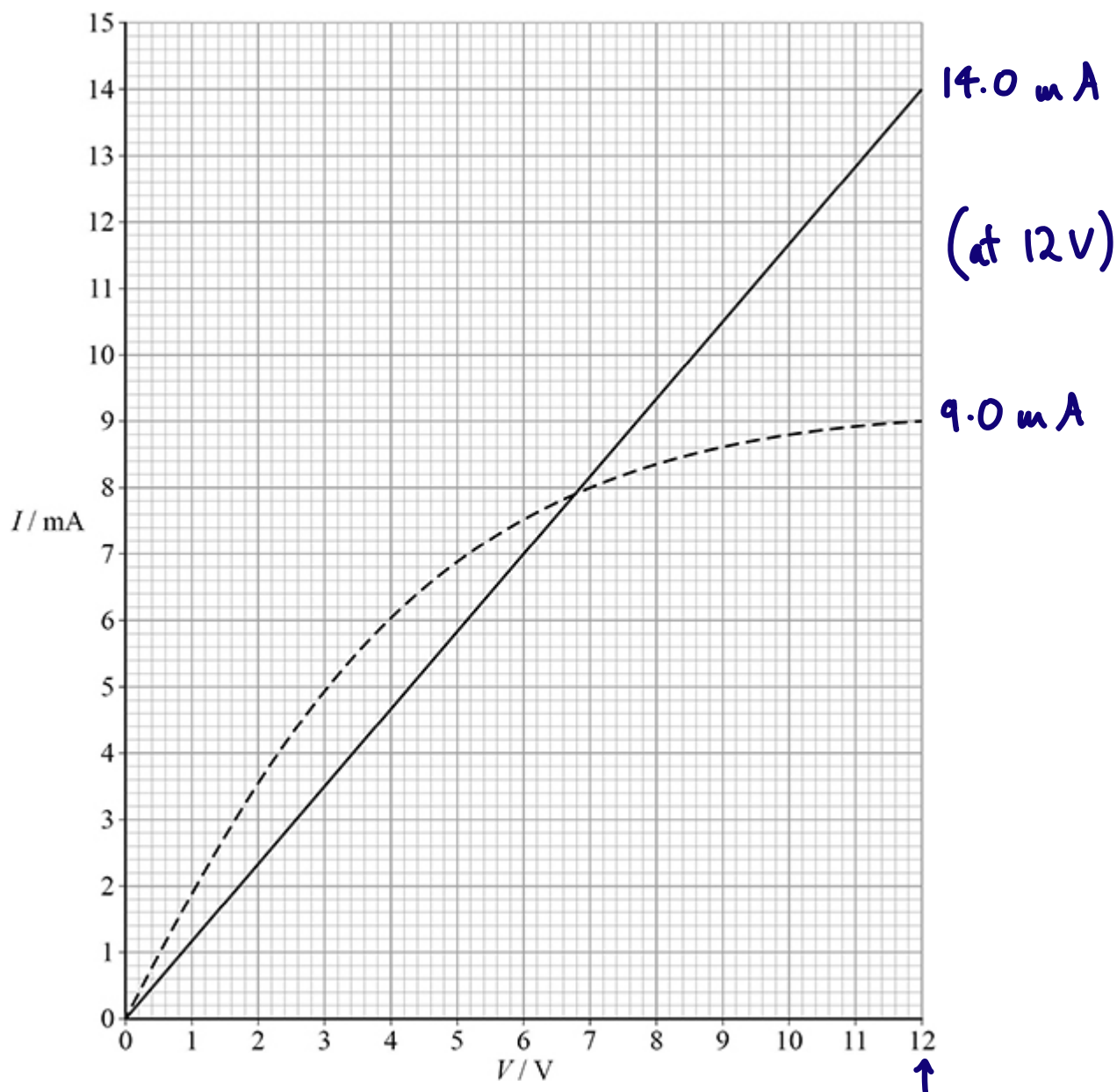

The two components are connected in parallel with a 12 V battery that has negligible internal resistance.

What is the current in the battery?

A 7.9 mA

$$I_T = I_1 + I_2$$

B 14.5 mA

$$I_T = 14.0 + 9.0 = 23.0 \text{ mA}$$

C 15.8 mA

D 23.0 mA

(Total 1 mark)

5. Measurements are taken to determine the resistivity of a uniform metal wire. The table shows the quantities measured and their percentage uncertainties.

Quantity	Percentage uncertainty
potential difference across wire	0.3%
current in wire	5.0%
diameter of wire	4.0%
length of wire	0.2%

What is the percentage uncertainty in the calculated value for the resistivity of the metal of the wire?

A 1.6%

B 9.5%

C 13.5%

D 21.5%

$$\rho = \frac{RA}{L} = \frac{V}{I} \times \frac{\pi d^2/4}{L}$$

$$\% \rho = \% V + \% I + (2 \times \% d) + \% L$$

$$\% \rho = 0.3 + 5.0 + (2 \times 4.0) + 0.2 = 13.5\%$$

(Total 1 mark)

6. Superconductors are used to

A increase the strength of electricity cables.

B make light dependent resistors.

C produce strong magnetic fields.

D increase the rate of heat energy transfer.

(Total 1 mark)

(low R ∴ high I ∴ high B field)

7. The battery in this circuit has an emf of 4.2 V and negligible internal resistance.

When open:  
 $\infty$  resistance in the circuit, so it measures V across the battery

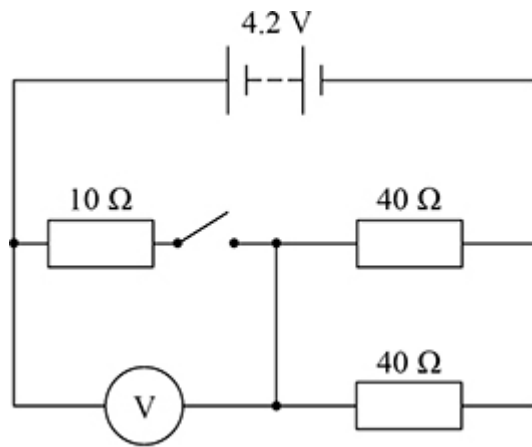

When closed:  
 40 Ω resistors in parallel have  $R_T$  of 20 Ω  
 $10:20 = 1:2$   
 $\therefore \frac{1}{1+2} \times 4.2 = 1.4 V$

What are the readings on the voltmeter when the switch is open (off) and when the switch is closed (on)?

	Open	Closed	
A	<del>0 V</del>	<del>2.1 V</del>	<input type="radio"/>
B	4.2 V	<del>2.1 V</del>	<input type="radio"/>
C	<del>0 V</del>	1.4 V	<input type="radio"/>
D	4.2 V	1.4 V	<input checked="" type="radio"/>

(Total 1 mark)

8. Two resistors X and Y are connected in series with a power supply of emf 30 V and negligible internal resistance.  
 The resistors are made from wire of the same material. The wires have the same length. X uses wire of diameter  $d$  and Y uses wire of diameter  $2d$ .

$$R \propto \frac{l}{A}$$

$$R \propto \frac{1}{d^2}$$

$$R_Y = \frac{1}{4} R_X$$

$$R_X = 4 R_Y$$

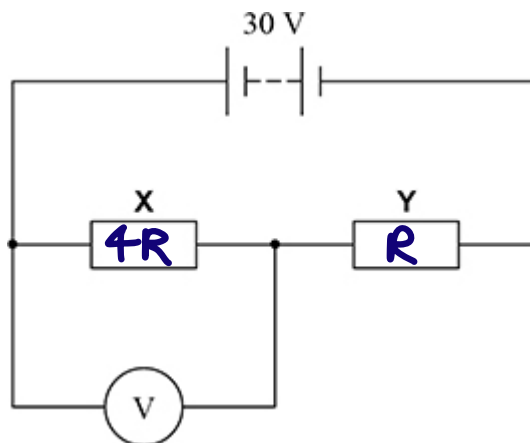

What is the reading on the voltmeter?

A 10 V

$$V_x = \frac{4}{4+1} \times 30 = 24V$$

B 15 V

C 20 V

D 24 V

(Total 1 mark)

9.

The table shows corresponding values of potential difference  $V$  and current  $I$  for four electrical components A, B, C and D.

	<del>A</del>	B	C	<del>D</del>
$V/V$	$I/A$	$I/A$	$I/A$	$I/A$
0	0.0	0.0	0.0	0.0
2	0.0	0.3	0.4	0.3
4	0.1	0.6	0.8	0.6
6	0.7	0.9	1.2	0.9
8	1.4	1.2	1.6	1.1
10	2.1	1.5	2.0	1.3
12	2.8	1.8	2.4	1.4

Which component is an ohmic conductor with the greatest resistance?

A

$$V \propto I \quad \therefore \text{Not A or D}$$

B

$$R = \frac{V}{I} \quad \therefore \text{For the same } V, \text{ a lower } I \text{ for a higher } R \therefore \text{not C}$$

C

D

(Total 1 mark)

10. Which row shows the resistances of an ideal ammeter and an ideal voltmeter?

	Ideal ammeter	Ideal voltmeter	
A	<del>infinite</del>	infinite	<input type="radio"/>
B	<del>infinite</del>	<del>zero</del>	<input type="radio"/>
<u>C</u>	zero	infinite	<input checked="" type="radio"/>
D	zero	<del>zero</del>	<input type="radio"/>

(Total 1 mark)

11. The capacity of a portable charger is rated in ampere hours (A h). A charger of capacity 1 A h can provide 1 A for 1 hour at its working voltage.

One charger has a capacity of 1800 mA h at a working voltage of 3.7 V.

What is the energy stored in this charger?

A 6.5 kJ

B 24 kJ

C 400 kJ

D 24 kJ

*E = ItV = 1.8 \times 60 \times 60 \times 3.7 = 23976 J = 24 kJ*

*B and D both correct!*

(Total 1 mark)

12. A filament lamp with resistance 12 Ω is operated at a power of 36 W.

How much charge flows through the filament lamp during 15 minutes?

A 26 C

B 1.6 kC

C 2.7 kC

D 6.5 kC

*P = I^2 R \quad I = \sqrt{\frac{P}{R}} = \sqrt{\frac{36}{12}} = \sqrt{3}*

*Q = It = \sqrt{3} \times 15 \times 60 = 1559 C = 1.6 kC*

(Total 1 mark)



13. The diagram shows a temperature-sensing circuit.

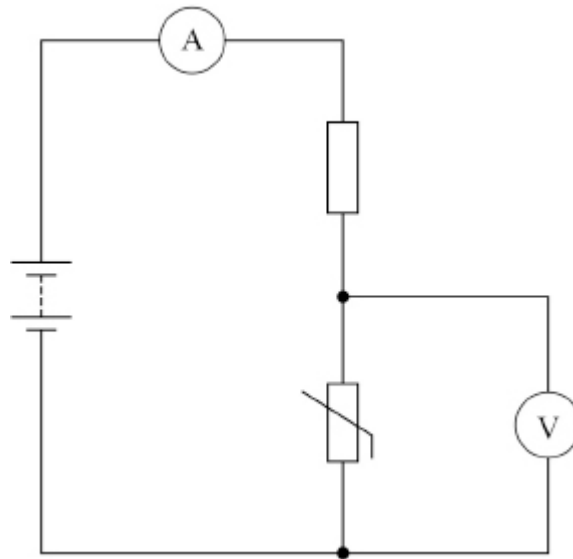

The temperature of the thermistor is decreased.  $\therefore R \uparrow$   $I \downarrow$  and  $V_{\text{thermistor}} \uparrow$

Which row shows the changes to the ammeter reading and the voltmeter reading?

	Ammeter reading	Voltmeter reading	
A	<del>increases</del>	increases	<input type="radio"/>
B	<del>increases</del>	<del>decreases</del>	<input type="radio"/>
C	decreases	<del>decreases</del>	<input type="radio"/>
<u>D</u>	decreases	increases	<input checked="" type="radio"/>

(Total 1 mark)

14. The potential difference between points X and Y is  $V$ .

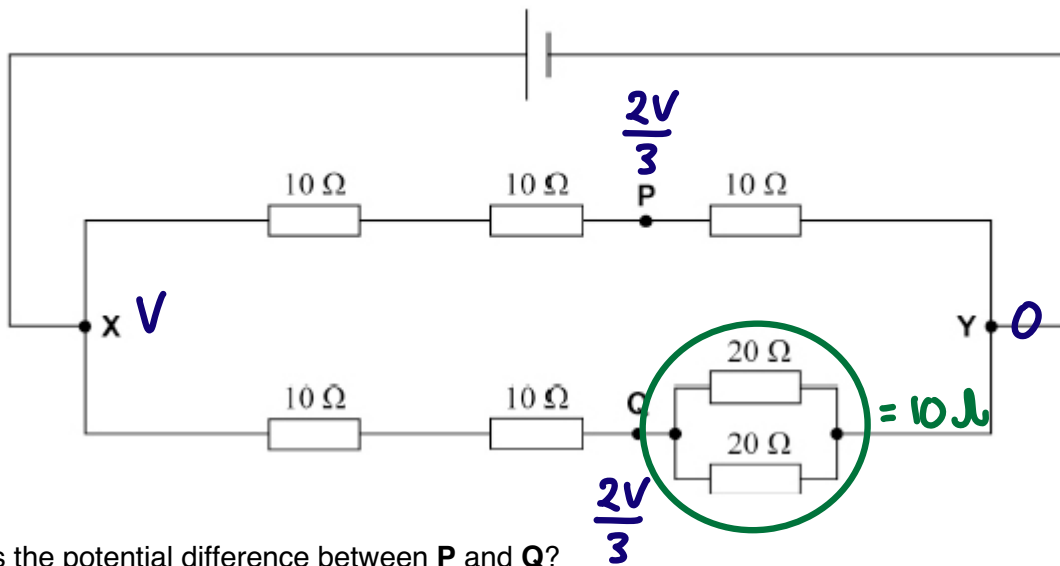

What is the potential difference between P and Q?

- A zero
- B  $\frac{V}{3}$
- C  $\frac{V}{2}$
- D  $\frac{2V}{3}$

P and Q both at  $\frac{2V}{3}$   
Between P and Q, pd = 0

(Total 1 mark)

15. A resistor with resistance  $R$  is made from metal wire of resistivity  $\rho$ . The length of the wire is  $L$ .

What is the diameter of the wire?

- A  $\sqrt{\frac{2\rho R}{\pi L}}$
- B  $\sqrt{\frac{2\rho L}{\pi R}}$
- C  $2\sqrt{\frac{\rho L}{\pi R}}$
- D  $2\sqrt{\frac{\rho R}{\pi L}}$

$$\rho = \frac{RA}{L} \quad A = \frac{\rho L}{R} \quad \text{and} \quad A = \frac{\pi d^2}{4}$$

$$\frac{\pi d^2}{4} = \frac{\rho L}{R} \quad d = \sqrt{\frac{4\rho L}{\pi R}}$$

$$d = 2\sqrt{\frac{\rho L}{\pi R}}$$

(Total 1 mark)

16.

A resistor of resistance  $R$  and three identical cells of emf  $E$  and internal resistance  $r$  are connected as shown.

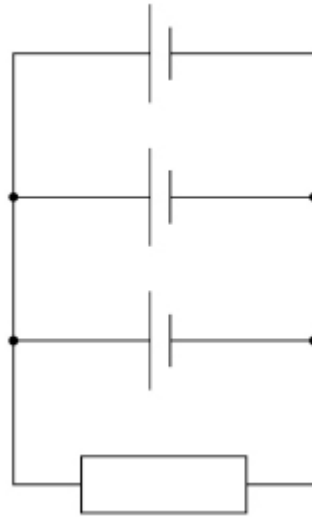

3 in parallel

$$\therefore r_T = \frac{r}{3}$$

What is the current in the resistor?

**A**  $\frac{3E}{(3R+r)}$

**B**  $\frac{9E}{(3R+r)}$

**C**  $\frac{E}{R}$

**D**  $\frac{3E}{R}$

$$E = I(R + r_T)$$

$$I = \frac{E}{R + r/3}$$

$$I = \frac{3E}{3R + r}$$

(Total 1 mark)

17. In the circuit, the reading of the voltmeter is  $V$ .

When the switch is closed the reading becomes  $\frac{V}{3}$ .

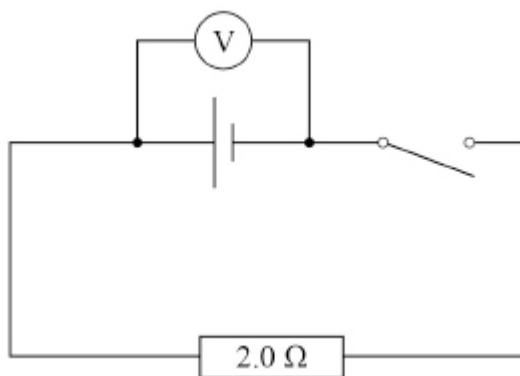

What is the internal resistance of the cell?

- A 0.33 Ω
- B 0.67 Ω
- C 4.0 Ω
- D 6.0 Ω

Closed switch  $V = \frac{E}{3}$   $R = 2.0$

$V = IR$

$\frac{E}{3} = I \times 2.0$

$I = \frac{E}{6}$

(Total 1 mark)

$E = V + Ir$

$E = \frac{E}{3} + \frac{E}{6} r$

$\div E \quad 1 = \frac{1}{3} + \frac{1}{6} r$

$\times 6 \quad 6 = 2 + r$

$r = 4$

18.

Which is the current–voltage characteristic graph for a filament lamp up to its working voltage?

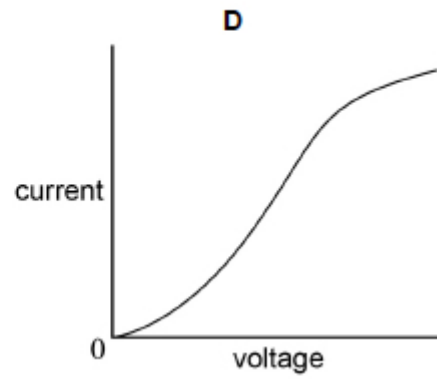
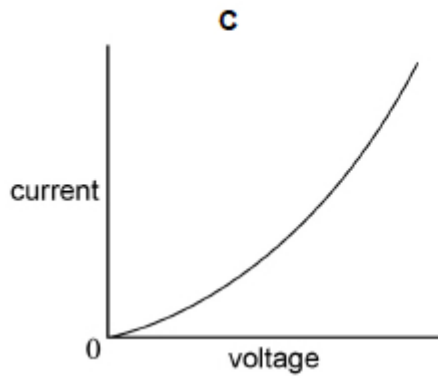
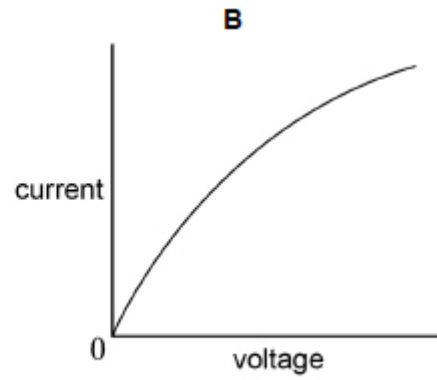
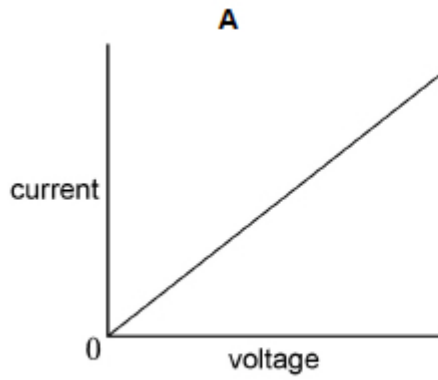

A

B

C

D

(Total 1 mark)

19.

Three identical cells, each of emf 1.5 V and internal resistance 6.0  $\Omega$ , are connected to resistor R. The resistance of R is 6.0  $\Omega$ .

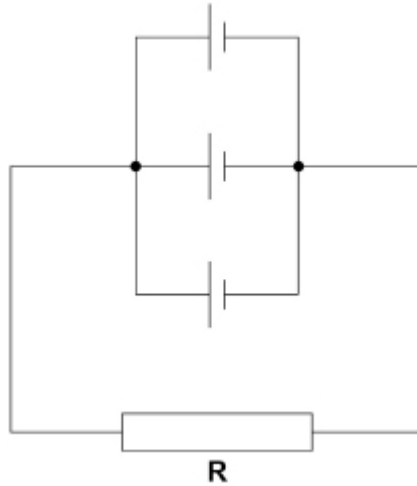

$$E = I(R + r)$$

$$I = \frac{E}{R + r/3}$$

$$I = \frac{3E}{3R + r}$$

What is the current in R?

A 0.19 A

B 0.25 A

C 0.56 A

D 0.75 A

$$I = \frac{3 \times 1.5}{(3 \times 6.0) + 6.0}$$

$$I = 0.1875 \text{ A}$$

(Total 1 mark)

20.

The diagram shows part of a circuit and the currents in the circuit.

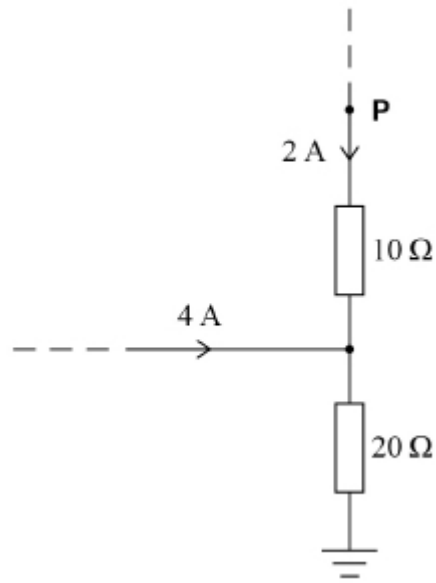

$$V = IR = 2 \times 10 = 20V$$

$$V = IR = 6 \times 20 = 120V$$

$$V_T = 20 + 120 = 140V$$

What is the potential difference between point P and earth?

A 60 V

B 100 V

C 120 V

D 140 V

(Total 1 mark)

21. Which graph shows how power dissipated  $P$  varies with current  $I$  in a component that obeys Ohm's law?

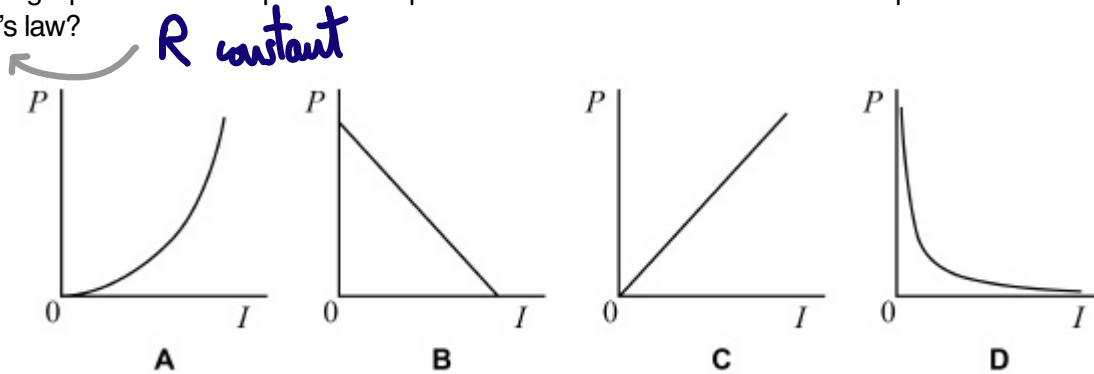

A

B

C

D

$$P = I^2 R$$

$$P \propto I^2$$

(Total 1 mark)

22. A gas containing doubly-charged ions flows to give an electric current of 0.64 A

How many ions pass a point in 1.0 minute?

A  $2.0 \times 10^{18}$

B  $4.0 \times 10^{18}$

C  $1.2 \times 10^{20}$

D  $2.4 \times 10^{20}$

$$Q = It = 0.64 \times 60 = 38.4 \text{ C}$$

$$n = \frac{Q}{q} = \frac{38.4}{2 \times 1.60 \times 10^{-19}}$$

$$= 1.2 \times 10^{20}$$

(Total 1 mark)



23.

A mobile phone operates at a constant power of 200 mW  
It has a 3.7 V lithium-ion battery that has a charge capacity of 9400 C

What is the time taken for the battery to discharge completely?

A 2 hours

**B** 48 hours

C 120 hours

D 140 hours

$$E = VQ = 3.7 \times 9400 = 34780 \text{ J}$$

$$t = \frac{E}{P} = \frac{34780}{0.200} = 173900 \text{ s}$$

$$\div 3600 = 48.3 \text{ hours}$$

(Total 1 mark)

24.

The two resistors shown are both uniform cylinders of equal length made from the same conducting putty.

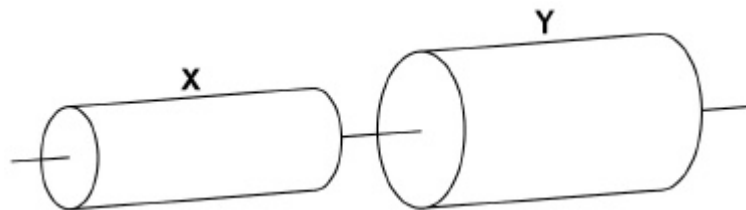

The diameter of Y is twice that of X. The resistance of Y is  $R$ .

What is the total resistance of the combination?

A  $\frac{4R}{5}$ B  $3R$ C  $4R$ **D**  $5R$ 

$$R \propto \frac{1}{d^2}$$

$$R_x = 4R_y$$

$$R_x + R_y = 4R + R = 5R$$

(Total 1 mark)

25. The combined resistance of  $n$  identical resistors connected in parallel is  $R_n$ .

$$\frac{1}{R_n} = \frac{1}{R_1} + \frac{1}{R_2} + \dots$$

Which statement correctly describes the variation of  $R_n$  as  $n$  increases?

- A  $R_n$  decreases linearly as  $n$  increases
- B**  $R_n$  decreases non-linearly as  $n$  increases
- C  $R_n$  increases linearly as  $n$  increases
- D  $R_n$  increases non-linearly as  $n$  increases

$R_n = \frac{R}{n}$   $R_n \propto \frac{1}{n}$   
 as  $n \uparrow$   $R_n \downarrow$   
 $\therefore$  non-linear

26. The table shows the resistivity, length and cross-sectional area of wires P and Q.

	resistivity	length	cross-sectional area
wire P	$\rho$	$L$	$A$
wire Q	$\frac{\rho}{4}$	$L$	$\frac{A}{2}$



The resistance of wire P is  $R$ .

What is the total resistance of the wires when they are connected in parallel?

- A  $\frac{R}{9}$
- B**  $\frac{R}{3}$
- C  $\frac{2R}{3}$
- D  $\frac{3R}{2}$

$R_p = \frac{\rho L}{A}$   $R_q = \frac{\rho/4 \cdot L}{A/2} = \frac{\rho L}{2A}$

$R_q = \frac{R_p}{2} = \frac{R}{2}$

$\frac{1}{R_T} = \frac{1}{R_p} + \frac{1}{R_q}$

$\frac{1}{R_T} = \frac{1}{R} + \frac{1}{R/2}$

$\frac{1}{R_T} = \frac{1}{R} + \frac{2}{R} = \frac{3}{R}$

$R_T = \frac{R}{3}$

(Total 1 mark)

27.

In this resistor network, the emf of the supply is 12 V and it has negligible internal resistance.

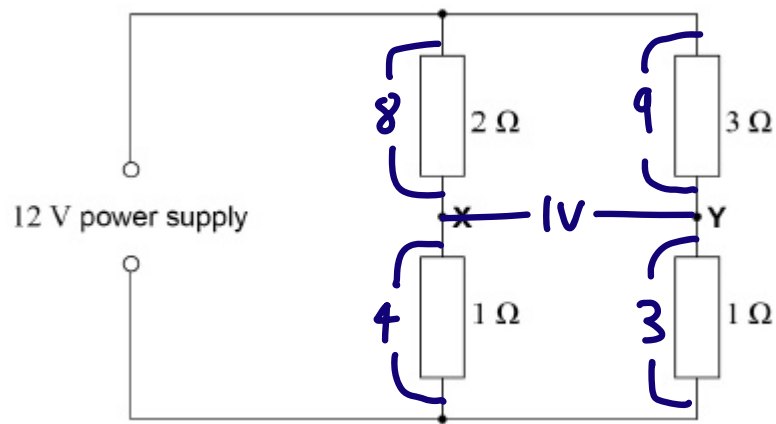

What is the reading on a voltmeter connected between points X and Y?

A 0 V

**B** 1 V

C 3 V

D 4 V

(Total 1 mark)

28.

Three cells each have an emf  $\epsilon = 1.5 \text{ V}$  and an internal resistance  $r = 0.6 \Omega$ .

Which combination of these cells will deliver a total emf of  $1.5 \text{ V}$  and a maximum current of  $7.5 \text{ A}$ ?

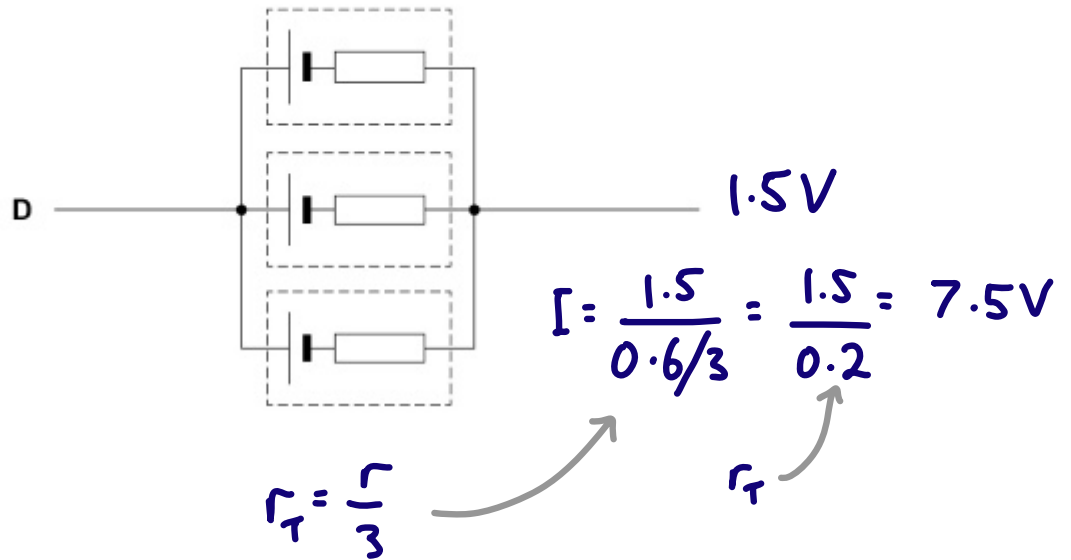
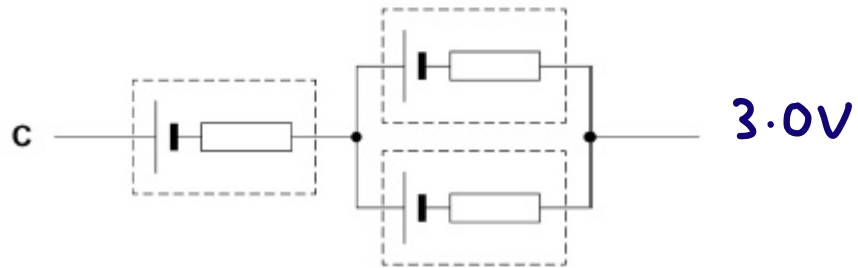
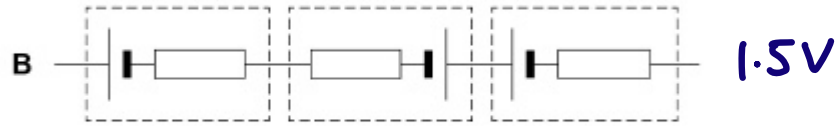
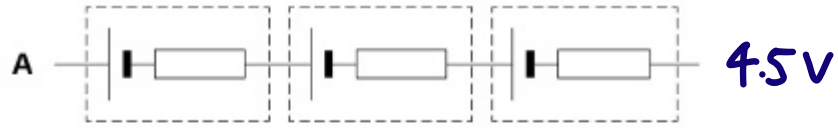

- A
- B
- C
- D

(Total 1 mark)

29.

Which graph shows the variation of the resistance with temperature for an ntc thermistor?

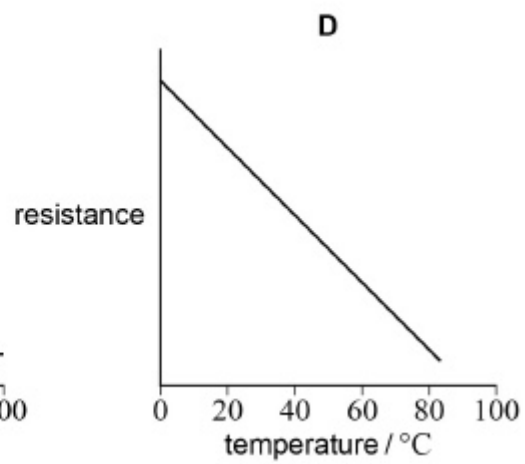
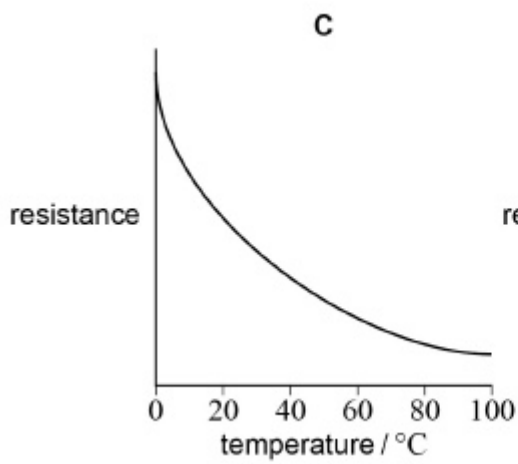
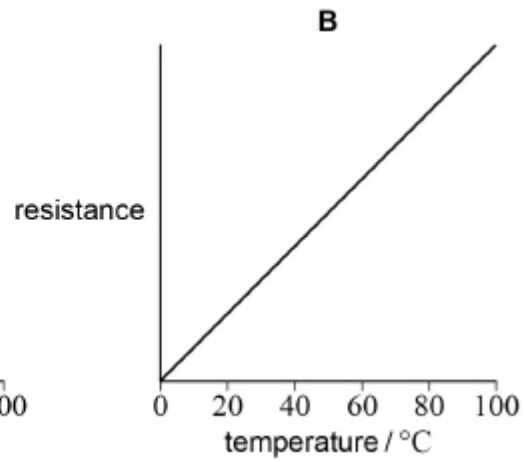
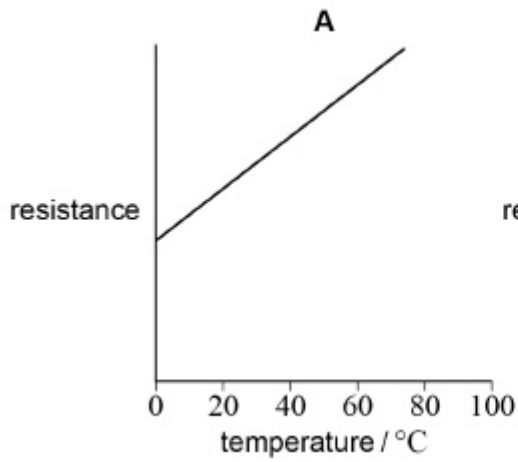

A

B

C

D

*T ↑ R ↓ non-linearly*

(Total 1 mark)

30. The figure shows a light dependent resistor (LDR) and fixed resistor R connected in series across a cell. The internal resistance of the cell is negligible.

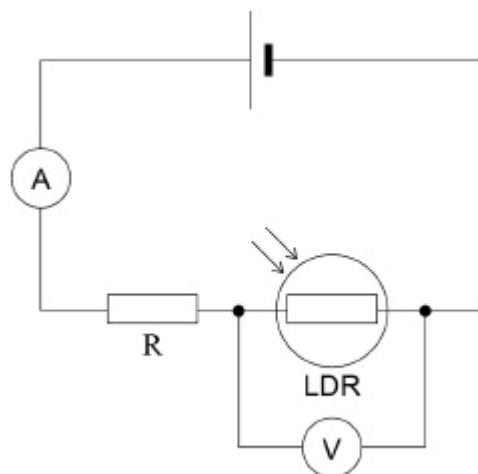

Which row shows how the readings on the ammeter and the voltmeter change when the light intensity incident on the LDR is increased?

Light  $\uparrow$   $R \downarrow$   $\therefore V \downarrow + I \uparrow$

	Ammeter reading	Voltmeter reading	
A	<del>decreases</del>	<del>increases</del>	<input type="checkbox"/>
B	<del>decreases</del>	decreases	<input type="checkbox"/>
C	increases	<del>increases</del>	<input type="checkbox"/>
<u>D</u>	increases	decreases	<input checked="" type="checkbox"/>

(Total 1 mark)

31.

In the circuit below, the potential difference across the light emitting diode (LED) is 1.8 V when it is emitting light.

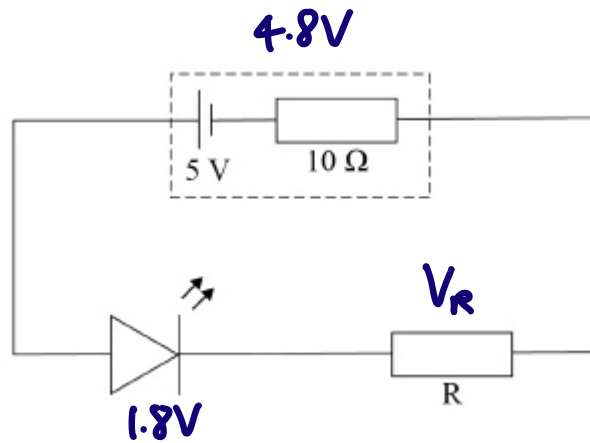

The current in the circuit is 20 mA.

What is the value of the resistor R?

A 80 Ω

B 90 Ω

C 150 Ω

D 160 Ω

$$V = E - Ir$$

$$V = 5 - (0.020 \times 10) = 4.8V$$

$$V_R = 4.8 - 1.8 = 3.0V$$

$$R = \frac{V_R}{I} = \frac{3.0}{0.020} = 150 \Omega$$

(Total 1 mark)

32. The graph shows how the potential difference  $V$  across an electrical component varies with current  $I$  in the component.

A tangent has been drawn on the curve at point  $P$  for a current of  $I_2$ .

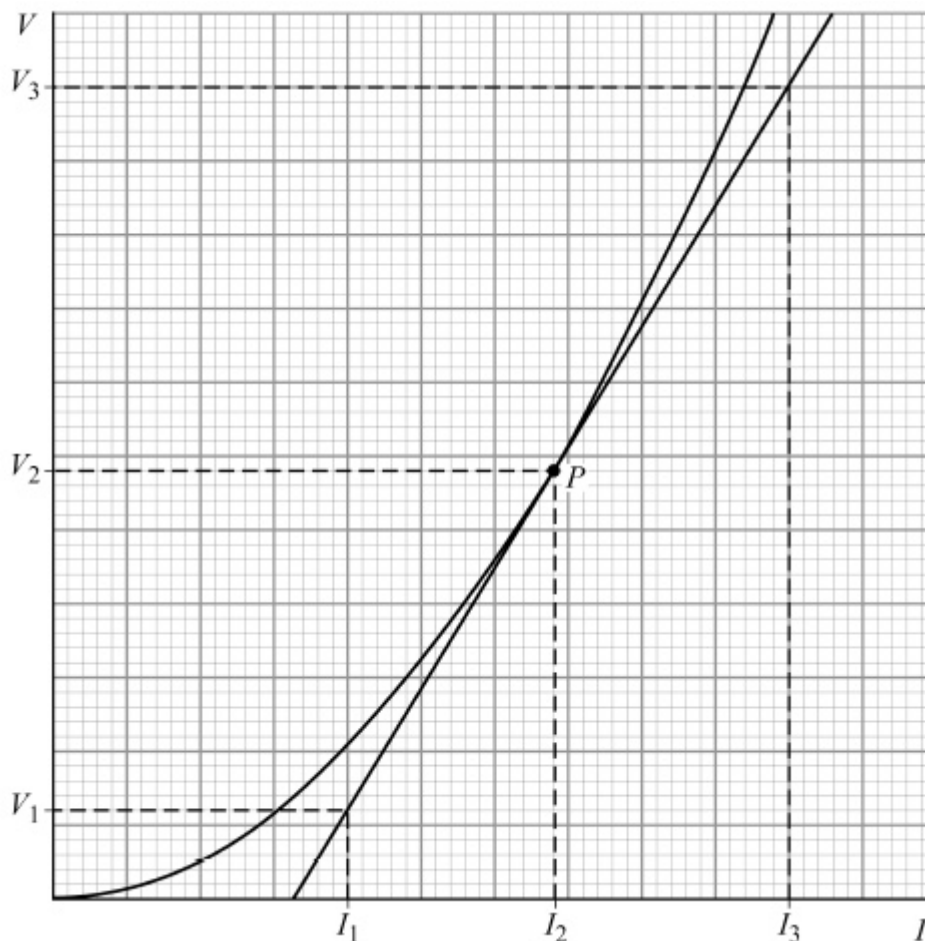

What is the resistance of the electrical component when the current in the component is  $I_2$ ?

A  $\frac{V_3 - V_1}{2I_2}$

Not the gradient!

B  $\frac{V_3 - V_1}{I_3 - I_1}$

Just point values

C  $\frac{V_2}{I_2}$

$R = \frac{V}{I}$  not  $\frac{\Delta V}{\Delta I}$

D  $\frac{2V_2}{I_2 - I_1}$

(Total 1 mark)



33.

A circuit consists of a cell, a thermistor, a fixed resistor and two ammeters.

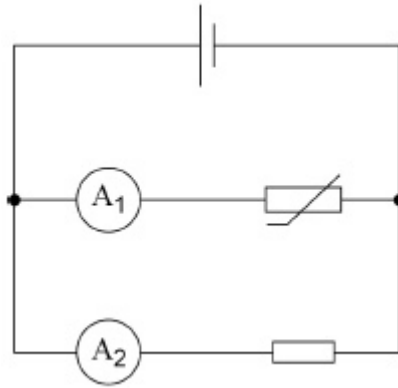

The cell has a constant electromotive force and negligible internal resistance. Readings from the two ammeters are taken.

Which row describes what happens to the current in each ammeter when the temperature of the thermistor decreases?

$T \downarrow$   $R_{Th} \uparrow$   $\therefore A_1 \downarrow$

$A_2$  unchanged as it has the same  $R$  and  $V$  as before

	Current in ammeter $A_1$	Current in ammeter $A_2$	
<u>A</u>	Decreases	Unchanged	<input checked="" type="radio"/>
B	Decreases	<del>Increases</del>	<input type="radio"/>
C	<del>Increases</del>	<del>Decreases</del>	<input type="radio"/>
D	<del>Increases</del>	Unchanged	<input type="radio"/>

(Total 1 mark)

34.

Two identical batteries each of emf 1.5 V and internal resistance 1.6  $\Omega$  are connected in parallel. A 2.4  $\Omega$  resistor is connected in parallel with this combination.

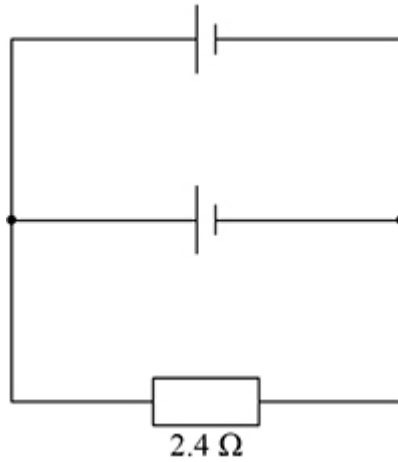

$$r_T = \frac{r}{2}$$

What is the current in the 2.4  $\Omega$  resistor?

A 0.38 A

B 0.47 A

C 0.75 A

D 0.94 A

$$I = \frac{E}{R + r} = \frac{1.5}{2.4 + (1.6/2)}$$

$$I = 0.46875 \text{ A}$$

(Total 1 mark)