

1.

The figure below shows the results of a test on an internal combustion engine which uses purified biogas.

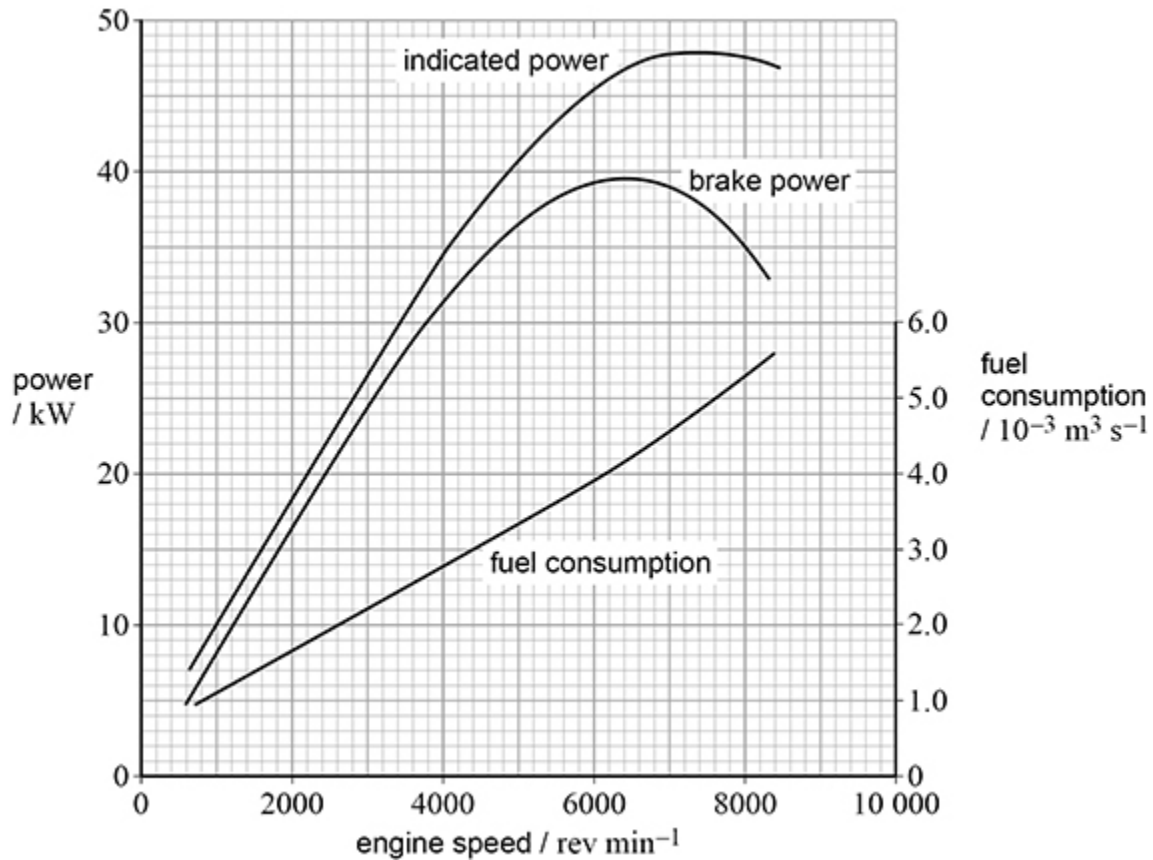

The figure above shows how the indicated power, brake (or output) power and fuel consumption of the engine vary with the engine speed. The scale on the left-hand axis is power and the scale on the right-hand axis is fuel consumption.

(a) The figure above can be used to analyse the performance of the engine.

Determine, for the speed at which the engine develops its maximum brake power:

- the overall efficiency
- the thermal efficiency
- the mechanical efficiency.

Go on to explain how knowledge of these efficiencies can be useful to an engineer.

calorific value of biogas used in the test = $32.3 \times 10^6 \text{ J m}^{-3}$

- (b) Explain why it is **not** advisable to run this engine at speeds above $7000 \text{ rev min}^{-1}$. Refer to the figure above in your answer.

(2)

(Total 8 marks)

2.

Figure 1 shows the p - V diagram for an idealised diesel engine cycle. In this cycle a fixed mass of air is taken through four processes $1 \rightarrow 2 \rightarrow 3 \rightarrow 4 \rightarrow 1$.

Figure 1

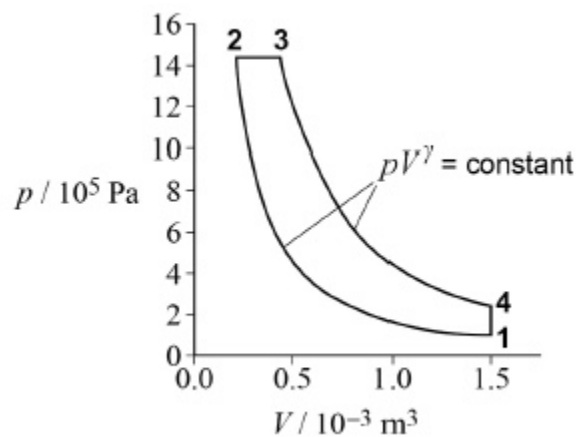

- (a) Which statement about this cycle is true?
Tick (✓) the correct answer.

Work is done by the air in process **4** → **1**.

Energy is supplied to the air by heating only in process **2** → **3**.

The temperature of the air rises in process **3** → **4**.

The area enclosed by the loop **1** → **2** → **3** → **4** → **1** is the power output of the cycle.

(1)

- (b) The cycle in **Figure 1** may be modified by allowing the air to continue to expand adiabatically from state **4** until it is at atmospheric pressure at state **5**.

Figure 2 shows the modified cycle.

Figure 2

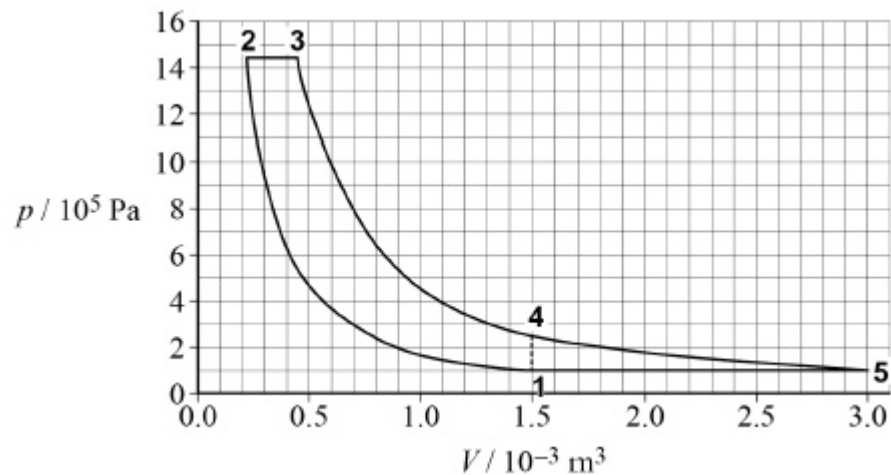

The expansion stroke **3** → **5** is now longer than the compression stroke **1** → **2**. Process **5** → **1** takes place at constant pressure.

It has been claimed that, compared to the cycle in **Figure 1**, the modified cycle of **Figure 2** gives

A an increase in work done per cycle of 130 J

B an increase in efficiency of more than 15%

Deduce whether these claims are true.

Claim **A**

Claim **B**

(5)

(c) The first law of thermodynamics can be written as

$$Q = \Delta U + W$$

State the meaning of the terms Q and ΔU in this equation.

Q _____

ΔU _____

(2)

- (d) For the air in process $5 \rightarrow 1$ in **Figure 2**, $\Delta U = -374 \text{ J}$

Calculate the energy that must be removed by cooling for process $5 \rightarrow 1$.

energy removed by cooling = _____ J

(2)

- (e) 0.060 mol of air is taken through the cycle.

Determine the maximum temperature in the cycle.

maximum temperature = _____ K

(3)

(Total 13 marks)

3.

The diagram shows a gas strut supporting the lid of a trailer.

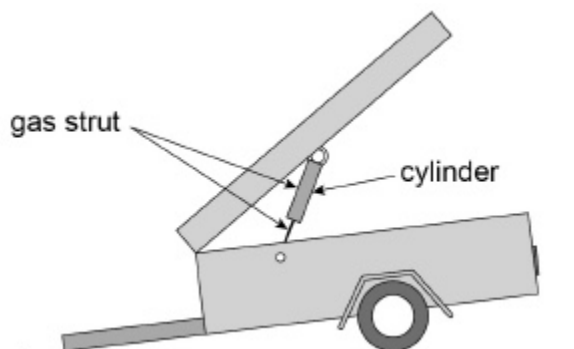

A fixed mass of nitrogen gas is sealed into the cylinder of the strut.

- (a) The gas is initially at a pressure of 1.2×10^6 Pa, a volume of $9.0 \times 10^{-5} \text{ m}^3$ and a temperature of 290 K.

When the lid is closed quickly the gas is compressed rapidly to a final volume of $6.8 \times 10^{-5} \text{ m}^3$.

Calculate the pressure and temperature of the gas at the end of the compression assuming the compression to be an adiabatic process.

adiabatic index γ for nitrogen = 1.4

pressure = _____ Pa

temperature = _____ K

(4)

- (b) Explain why the rapid compression of the gas can be assumed to be an adiabatic process.

(2)

- (c) When the lid is closed slowly, the compression can be assumed to be isothermal.

The gas can be compressed either isothermally or adiabatically from the same initial conditions to the same final volume.

Compare without calculation the work done in each process.

(3)

(Total 9 marks)

4. The diagram shows the $p - V$ diagram for a theoretical petrol engine cycle compared to the indicator diagram for a real four-stroke petrol engine with the same maximum and minimum volumes.

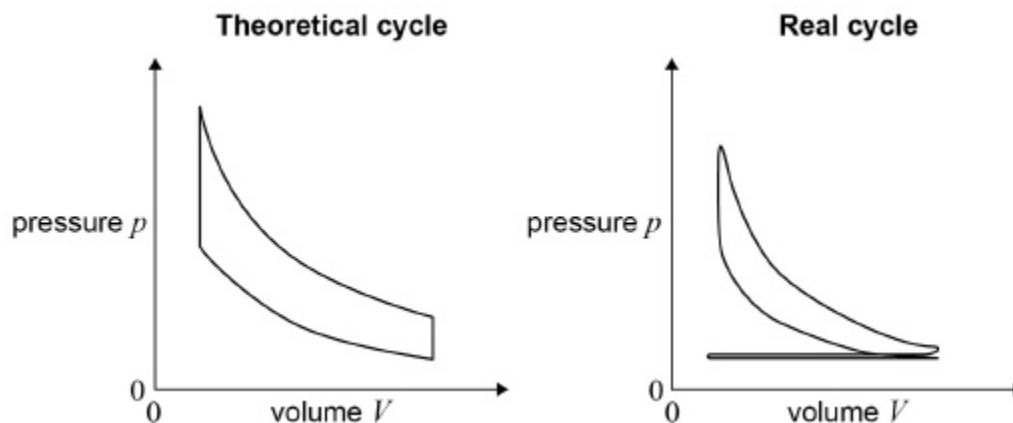

Compare the theoretical and real engine cycles. In your answer you should:

- state and explain the differences between the cycles
- explain why the work output per cycle of the real engine is less than that predicted by an analysis of the theoretical cycle.

(Total 6 marks)

(Total 6 marks)

6.

Figure 1 shows a tool for driving nails into wood. Only part of the tool is shown.

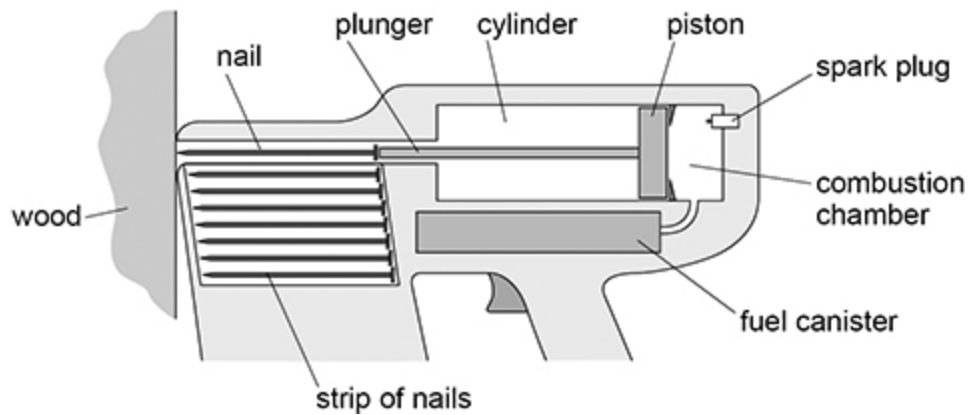
Figure 1

Fuel is mixed with air in the combustion chamber and is ignited by a spark. The gas expands rapidly and drives the piston along the cylinder. The plunger attached to the piston drives the nail into the wood.

The table below shows the average force needed to drive nails of various lengths completely into a particular type of wood.

Nail	Length / mm	Average force / N
A	32	250
B	38	320
C	45	370
D	50	420
E	63	560

- (a) **Figure 2** shows the variation of pressure p with volume V as the gas expands on the right-hand side of the piston when the correct nail is used.

Figure 2

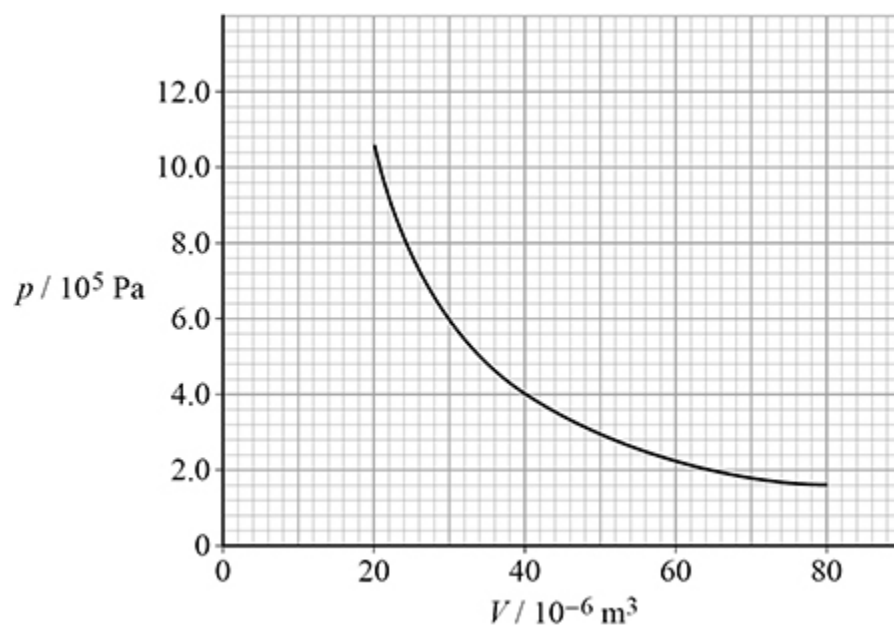

The combustion chamber has a volume of $20 \times 10^{-6} \text{ m}^3$ and the piston moves through a volume of $60 \times 10^{-6} \text{ m}^3$.

The work done by the expanding gas is just enough to drive the correct nail completely into the wood.

Deduce which nail in the table above is the correct one to use in the tool.

- (b) After a nail has been used, another nail takes its place automatically. The tool can drive up to 180 nails per minute.

Discuss why the expansion **cannot** be isothermal.

(3)

(Total 8 marks)

7.

The figure shows some of the equipment used to investigate the thermal and mechanical efficiencies of a single-cylinder four-stroke petrol engine.

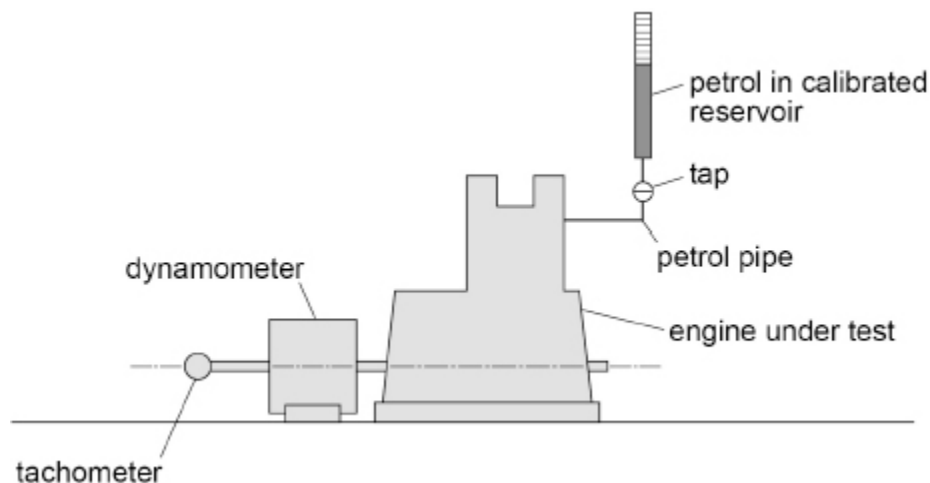

- Petrol is supplied to the engine from a calibrated reservoir.
- Sensors are used to measure the volume V and pressure p above the piston inside the cylinder.
- The dynamometer applies a load to the output shaft and measures the output torque of the engine.
- The tachometer measures the rotational speed of the engine in revolutions per second.

In one test the air intake valve (throttle) setting remains fixed and the load provided by the dynamometer is kept constant.

Describe how you would determine the input power, the indicated power, the brake power, the thermal efficiency and the mechanical efficiency.

In your answer you should

- describe the measurements that you would take
- show how you would use the measurements and any other necessary data.

(Total 6 marks)

8.

- (a) An ideal heat pump and an ideal refrigerator operate between the same hot and cold spaces.

Which statement relating to the coefficient of performance (COP) is correct?

Tick (✓) the correct answer.

The COP of the refrigerator must be < 1 .

The COP of the heat pump must be greater than the COP of the refrigerator.

The COP of the heat pump will increase if the temperature of the hot space is increased.

The COP of the refrigerator will decrease if the cold space temperature increases.

(4)

- (b) An ideal refrigerator operates between a cold space at a temperature of $-1\text{ }^{\circ}\text{C}$ and a hot space at a temperature of $70\text{ }^{\circ}\text{C}$.

Calculate the input power to the refrigerator if the rate of transfer of energy to the hot space is 100 W .

input power = _____ W

(3)

(Total 4 marks)

9.

- (a) Which is a correct statement about an ideal heat engine?

Tick (✓) **one** box.

The efficiency is increased when the kelvin temperatures of the hot source and the cold sink are increased by equal amounts.

The maximum efficiency depends on the p - V cycle.

The efficiency is 50% when the kelvin temperature of the hot source is twice the kelvin temperature of the cold sink.

(1)

- (b) An ideal heat engine has an efficiency of 0.33
The same engine works in reverse as an ideal refrigerator between the same hot and cold spaces.

Determine the coefficient of performance COP_{ref} of the refrigerator.

$$COP_{\text{ref}} = \underline{\hspace{2cm}}$$

(2)

(Total 3 marks)

10.

Tumble-dryers blow hot air over wet clothes that are moving in a rotating drum. Conventional tumble-dryers heat the air in the drum electrically; other dryers use a heat pump to heat the air.

- (a) A typical conventional tumble-dryer uses about 0.6 kW h per kg of clothes.
A heat pump tumble-dryer uses about 0.25 kW h per kg.

Explain why the heat pump tumble-dryer uses less electrical energy than the conventional tumble-dryer to dry the same load.

(2)

- (b) The cold space of the heat pump is the room in which the tumble-dryer is placed.

The hot space is the air in the tumble-dryer and is at a temperature of $160\text{ }^{\circ}\text{C}$.

A heat pump tumble-dryer can be placed in a kitchen at a temperature of $20\text{ }^{\circ}\text{C}$, or in a garage at around $5\text{ }^{\circ}\text{C}$.

Deduce which place would result in lower running costs for the tumble-dryer.

Support your answer with calculations.

(3)

(Total 5 marks)

11.

In an ideal heat-engine cycle a fixed mass of air is taken through the following four processes.

- A** \rightarrow **B** isothermal compression from an initial pressure of $1.0 \times 10^5\text{ Pa}$ and a volume of $9.0 \times 10^{-2}\text{ m}^3$ to a pressure of $2.2 \times 10^5\text{ Pa}$. The work done on the air is 7100 J .
- B** \rightarrow **C** increase in volume at constant pressure to a volume of $5.9 \times 10^{-2}\text{ m}^3$.
- C** \rightarrow **D** isothermal expansion to a pressure of $1.0 \times 10^5\text{ Pa}$ and a volume of $13 \times 10^{-2}\text{ m}^3$. The work done by the air is $10\,300\text{ J}$.
- D** \rightarrow **A** reduction in volume at constant pressure to the original volume.

The graph below shows the cycle

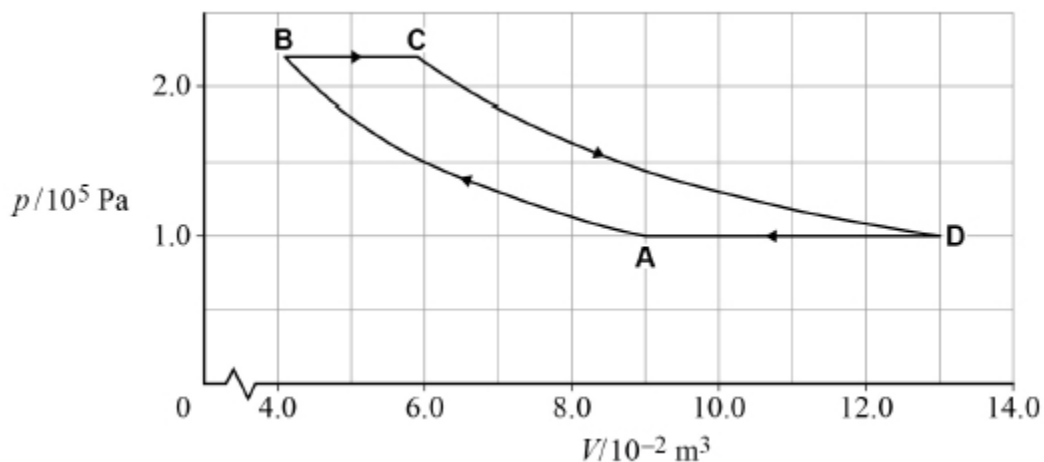

- (a) Show, by calculation, that the volume at **B** is $4.1 \times 10^{-2} \text{ m}^3$.

(1)

- (b) The temperature of the air between **A** and **B** is 295 K.

Show that the temperature of the air at **C** is about 420 K.

(2)

- (c) An ideal engine based on this cycle uses a device called an economiser. The economiser stores all the energy transferred in the cooling process **D** \rightarrow **A** and gives up all this energy to the air in process **B** \rightarrow **C**. This means that an external source supplies energy to the air by heating only in process **C** \rightarrow **D**.

Complete the table to show the values of work done W and energy transfer Q in each of the four processes.

Use the space below the table for any calculations.

Use a consistent sign convention.

Process	Work done W / J	Energy transfer Q / J
A → B	-7100	-7100
B → C	4000	
C → D	10 300	10 300
D → A		-14 000

(1)

(d) Explain why W is equal to Q in process **A → B** and in process **C → D**.

(2)

- (e) It is claimed that the efficiency of this engine cycle is the same as the maximum theoretical efficiency of a heat engine operating between the same temperatures.

Deduce whether this claim is true.

(3)

- (f) Discuss **one** problem that would be faced by an engineer designing a real engine based on this cycle.

(3)

(Total 12 marks)

12.

- (a) Explain how the second law of thermodynamics predicts that a heat engine can never be 100% efficient.

(2)

- (b) A company plans to build a geothermal power station in a region where there is hot rock deep below the surface. The scheme is shown in the figure.

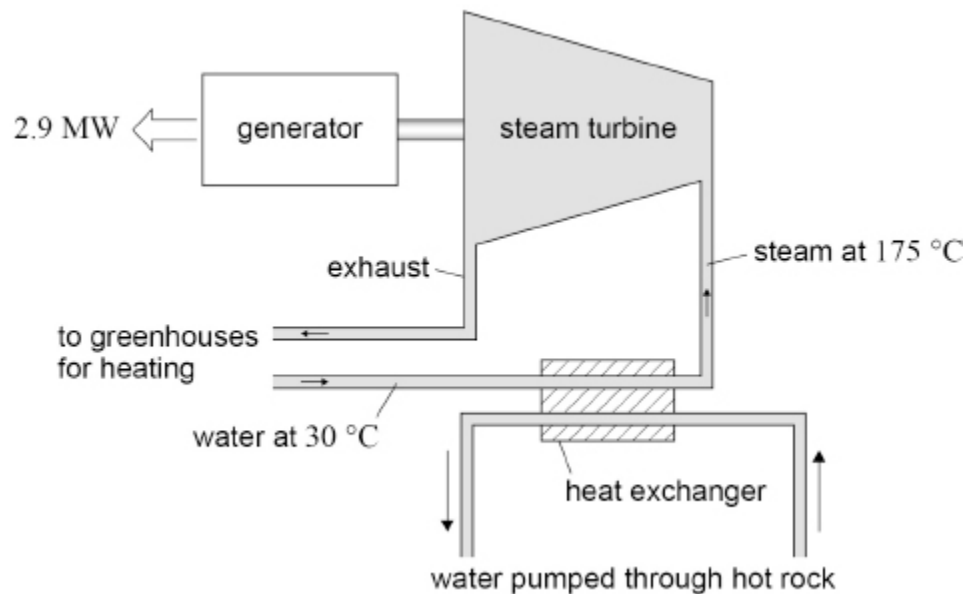

In the heat exchanger, energy from the hot rock is used to produce steam at $175\text{ }^{\circ}\text{C}$. The steam passes through a turbine that drives an electric generator. The exhaust steam is used to heat nearby greenhouses where it condenses before returning to the heat exchanger.

The lowest temperature in the turbine cycle is $30\text{ }^{\circ}\text{C}$.

The company claims that when the electrical power output is 2.9 MW , the power station will provide 6.4 MW for heating the greenhouses.

Deduce whether this claim is likely to be true.
Treat the power station as an ideal heat engine which obeys the second law of thermodynamics.

(4)

(Total 6 marks)

13.

(a) Which row in the table below shows

- **Process 1** in which work done is zero, and
- **Process 2** in which the change in internal energy is zero?

Tick (✓) **one** box.

Process 1	Process 2	
constant pressure	isothermal	<input type="checkbox"/>
constant volume	adiabatic	<input type="checkbox"/>
constant pressure	adiabatic	<input type="checkbox"/>
constant volume	isothermal	<input type="checkbox"/>

(1)

- (b) When irregular particles are packed, air gaps are left between the particles.
The true volume of a quantity of irregular particles must be determined using a method that does not include the volume of the air spaces between them.

The apparatus shown in **Figure 1** is used by an agricultural engineer to measure the true volume of some grains.

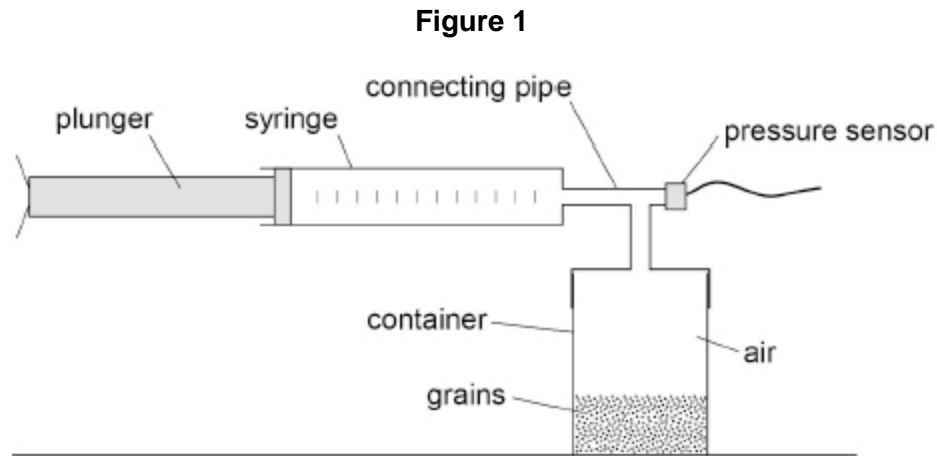

The volume of air in the syringe is $1.00 \times 10^{-4} \text{ m}^3$.

The volume of the **empty** container and connecting pipe is $2.80 \times 10^{-4} \text{ m}^3$.

Grains of total true volume V are now placed in the container and the lid is screwed on.

The pressure inside both the syringe and the container is $1.01 \times 10^5 \text{ Pa}$.

The plunger is slowly pushed fully into the cylinder of the syringe, compressing the air isothermally.

The pressure increases to $1.83 \times 10^5 \text{ Pa}$.

Determine V .

$$V = \text{_____} \text{ m}^3$$

(3)

Figure 2 shows how the pressure in the container and syringe varies with volume as the plunger is pushed in fully very slowly.

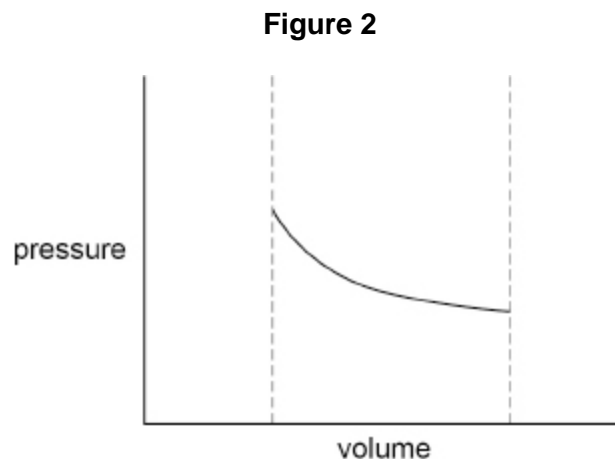

- (c) Sketch on **Figure 2** the variation of pressure with volume when the plunger is pushed in fully very quickly and then left for several seconds. Assume no leakage past the plunger.

(2)

- (d) Explain why the compression of a gas can be considered to be an isothermal change when the gas is compressed very slowly.

(2)

(Total 8 marks)