

1.

This question is about the measurement of the wavelength of laser light. The light is shone onto a diffraction grating at normal incidence. The light transmitted by the diffraction grating produces five spots on a screen. These spots are labelled **A** to **E** in **Figure 1**.

**Figure 1**

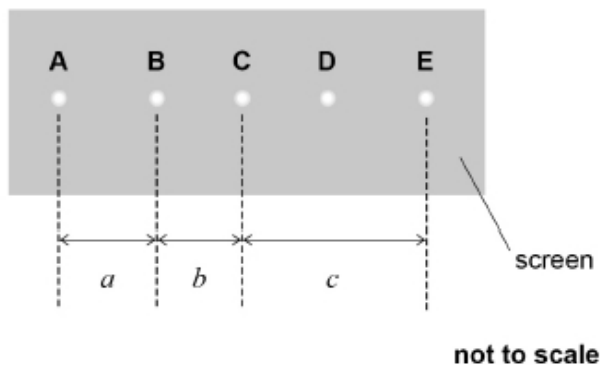

A student uses a metre ruler with 1 mm divisions to take readings. He uses these readings to obtain measurements  $a$ ,  $b$  and  $c$ , the distances between centres of the spots as shown in **Figure 1**.

**Table 1** shows his measurements and his estimated uncertainties.

**Table 1**

Measurement	Distance / mm	Uncertainty / mm
$a$	289	2
$b$	255	2
$c$	544	2

- (a) Explain why the student's estimated uncertainty in measurement  $a$  is greater than the smallest division on the metre ruler. You should refer to the readings taken by the student in obtaining this measurement.

---

---

---

---

---

---

---

---

---

---

- (b) The distance between the centres of spots **A** and **C** and the distance between the centres of spots **C** and **E** are equal.  
That is:

$$a + b = c$$

Calculate the percentage uncertainty in the sum of  $a$  and  $b$ .

percentage uncertainty = \_\_\_\_\_

(2)

- (c) Discuss why the experimental measurements lead to a different percentage uncertainty in  $c$  compared to that in  $a + b$ .

---

---

---

---

---

---

---

(2)

- (d) Eye protection should be used to prevent eye damage when using a laser.

Describe **one** other safety measure to minimise the risk of eye damage when using a laser in the laboratory.

---

---

---

(1)

- (e) **Figure 2** shows the experimental arrangement with  $y$ , the perpendicular distance between the diffraction grating and the screen, equal to 1.280 m.

**Table 2** shows some of the data from **Table 1**.

**Table 2**

Measurement	Distance / mm
$a$	289
$b$	255
$c$	544

**Figure 2**

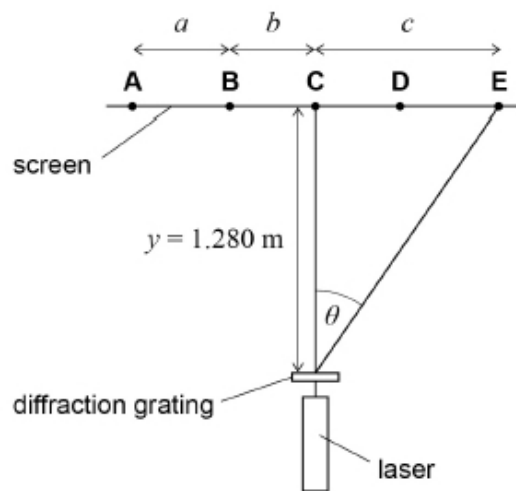

Calculate the angle  $\theta$  shown on **Figure 2**.

$$\theta = \text{_____ degrees}$$

(1)

- (f) Spot **E** is the second-order maximum.  
The diffraction grating has  $3.00 \times 10^5$  lines per metre.

Calculate the wavelength of the laser light.

$$\text{wavelength} = \text{_____ m}$$

...

- (g) The student plans to repeat the experiment using the same diffraction grating and laser.

State and explain **one** way the student can change the experimental arrangement to reduce the percentage uncertainty in the measurement of the wavelength.

Assume the percentage uncertainty in  $\sin \theta$  is the sum of the percentage uncertainties in  $y$  and  $c$ .

---



---



---



---



---



---

(2)

(Total 12 marks)

2.

Measurements are made to determine the tension, length and mass per unit length of a string stretched between two supports. The percentage uncertainties in these measurements are shown below.

Quantity	Percentage uncertainty
Length	0.80%
Tension	4.0%
Mass per unit length	2.0%

A stationary wave is formed on the string.

What is the percentage uncertainty in the calculated value of the frequency of the first harmonic?

A 1.8%

B 3.8%

C 6.8%

D 13%

(Total 1 mark)

3. **Figure 1** shows apparatus used to investigate the rate at which water flows through a horizontal cylindrical tube **T** of internal diameter  $d$  and length  $L$ .

**Figure 1**

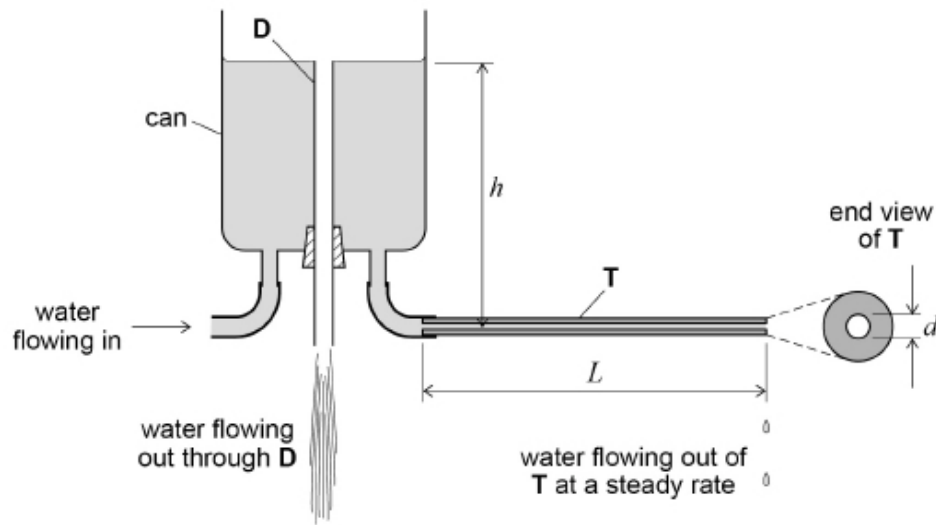

The apparatus ensures that the water level in the can is at a constant height  $h$  above the centre of **T**.

Water flows out of **T** at a steady rate.

- (a) The volume flow rate through **T** is  $Q$ , where  $Q$  is in  $\text{m}^3 \text{s}^{-1}$ .  
A student wants to measure  $Q$  as water flows through **T**.

Outline a procedure the student should follow to measure  $Q$ .

Include in your answer

- the measuring instruments used
- how uncertainty in the measurements can be reduced.

---

---

---

---

---

---

---

---

---

---

---

---

---

---

---

---

---

---

---

---

---

---

---

---

(b) It can be shown that

$$Q = \frac{\pi \rho g h d^4}{128 L \eta}$$

where  $\rho$  is the density of water

$g$  is the gravitational field strength

$\eta$  is a property of the water called the coefficient of viscosity.

What is the SI unit for  $\eta$ ?

Tick (✓) **one** box.

N m<sup>-1</sup> s

N m<sup>-2</sup> s

N m<sup>-1</sup> s<sup>-1</sup>

N m<sup>-2</sup> s<sup>-1</sup>

(1)

(c) An experiment is carried out to determine  $\eta$  by a graphical method.

The rate at which water flows out of **T** is varied by adjusting the height of the drain tube as shown in **Figure 2**.

**Figure 2**

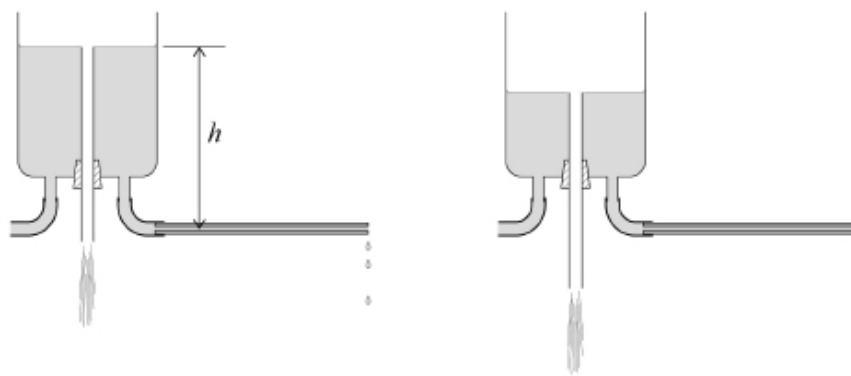

During the experiment the temperature is kept constant.

$Q$  is found for different values of  $h$  and a graph of these data is plotted, with  $Q$  on the vertical axis.

The percentage uncertainty in the gradient of the graph is 6.4%.

The dimensions of tube **T** are measured and the uncertainties in these data are calculated.

The percentage uncertainty

- in  $d$  is 2.9%
- in  $L$  is 1.8%.

The percentage uncertainties in  $\rho$  and  $g$  are negligible.

Deduce the percentage uncertainty in the result for  $\eta$ .

percentage uncertainty in  $\eta$  = \_\_\_\_\_

(2)



- (d) In a different experiment, the horizontal tube **T** is connected to a vertical glass tube. Marks have been made at regular intervals on the glass tube. The student measures and records the vertical distance  $y$  between each of the marks and the centre of **T**.

She seals the open end of **T** and fills the glass tube with water, as shown in **Figure 3**.

**Figure 3**

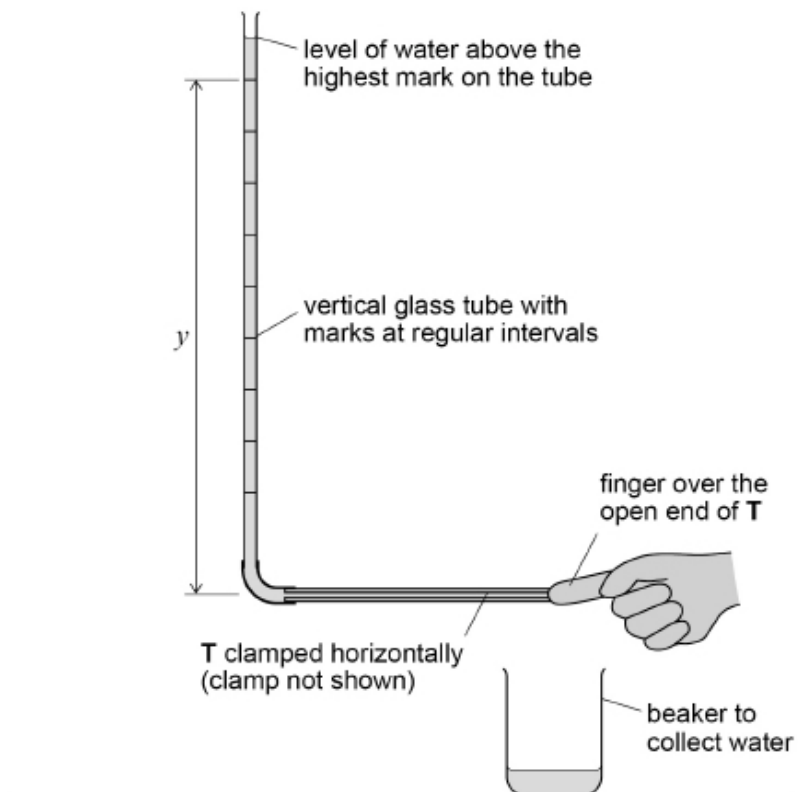

**T** is opened and water flows into a beaker. When the water level falls to the highest mark on the tube, she starts a stopwatch. She records the time  $t$  for the water to reach each of the other marks.

Explain how the student could check that the glass tube was vertical. You may wish to add detail to **Figure 3** to illustrate your answer.

---

---

---

---

(e) **Figure 4** shows part of the graph drawn from the student's data.

**Figure 4**

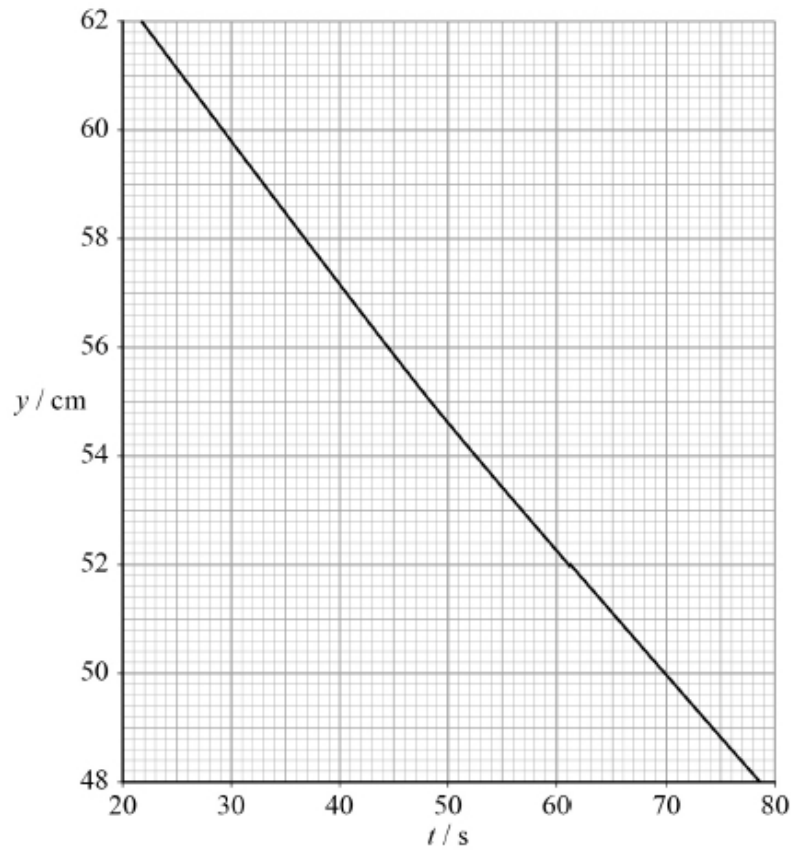

It can be shown that  $y$  decreases exponentially with  $t$ .

Show that  $\lambda$ , the decay constant for this process, is about  $4.5 \times 10^{-3} \text{ s}^{-1}$ .

$$\lambda = \underline{\hspace{2cm}} \text{ s}^{-1}$$

(2)

- (f)  $T_{1/2}$  is the time for  $y$  to decrease by 50%, as shown in **Figure 5**.

**Figure 5**

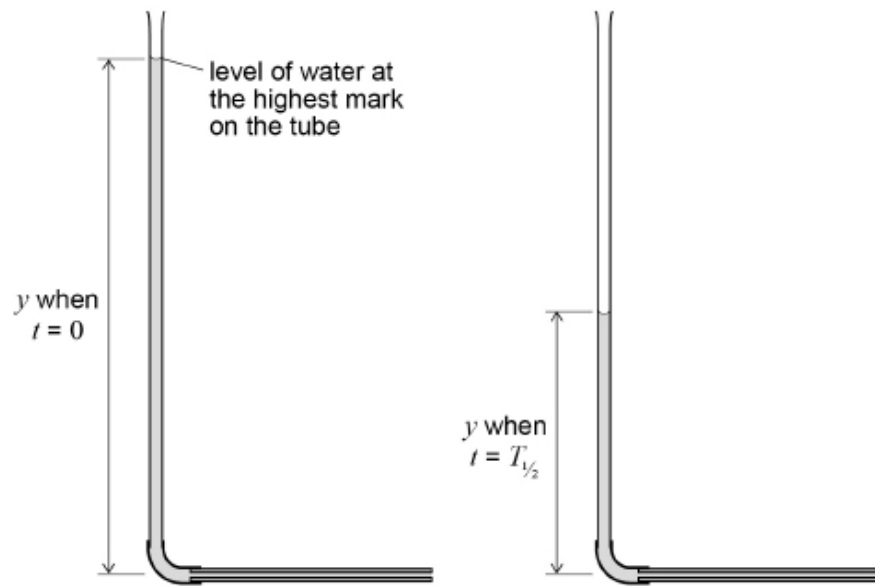

$T_{1/2} = \text{_____} \text{ s}$

(1)

- (g) The apparatus is adjusted so that the glass tube is inclined at  $30^\circ$  to the horizontal tube T, as shown in **Figure 6**.

**Figure 6**

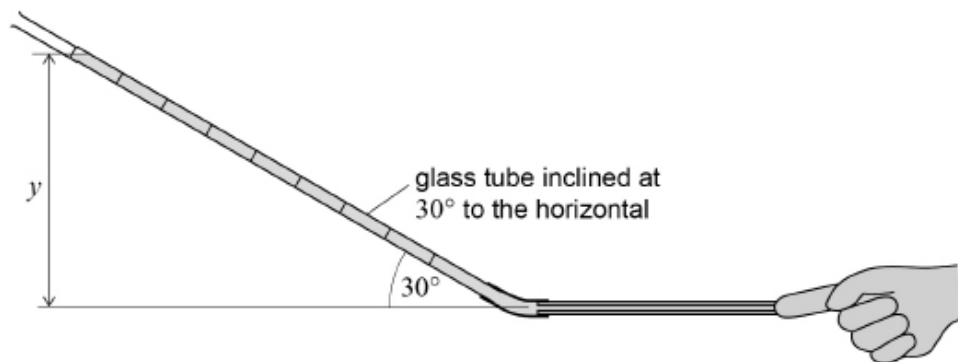

The student measures and records the new values of  $y$ , the mean vertical distance between each of the marks and the centre of **T**.

She then carries out the experiment as before, recording new values of  $t$  corresponding to each new value of  $y$ .

Draw a line on **Figure 7** to show the graph produced using the modified apparatus. The dashed line is the original graph when the glass tube was vertical as shown in **Figure 3**.

**Figure 7**

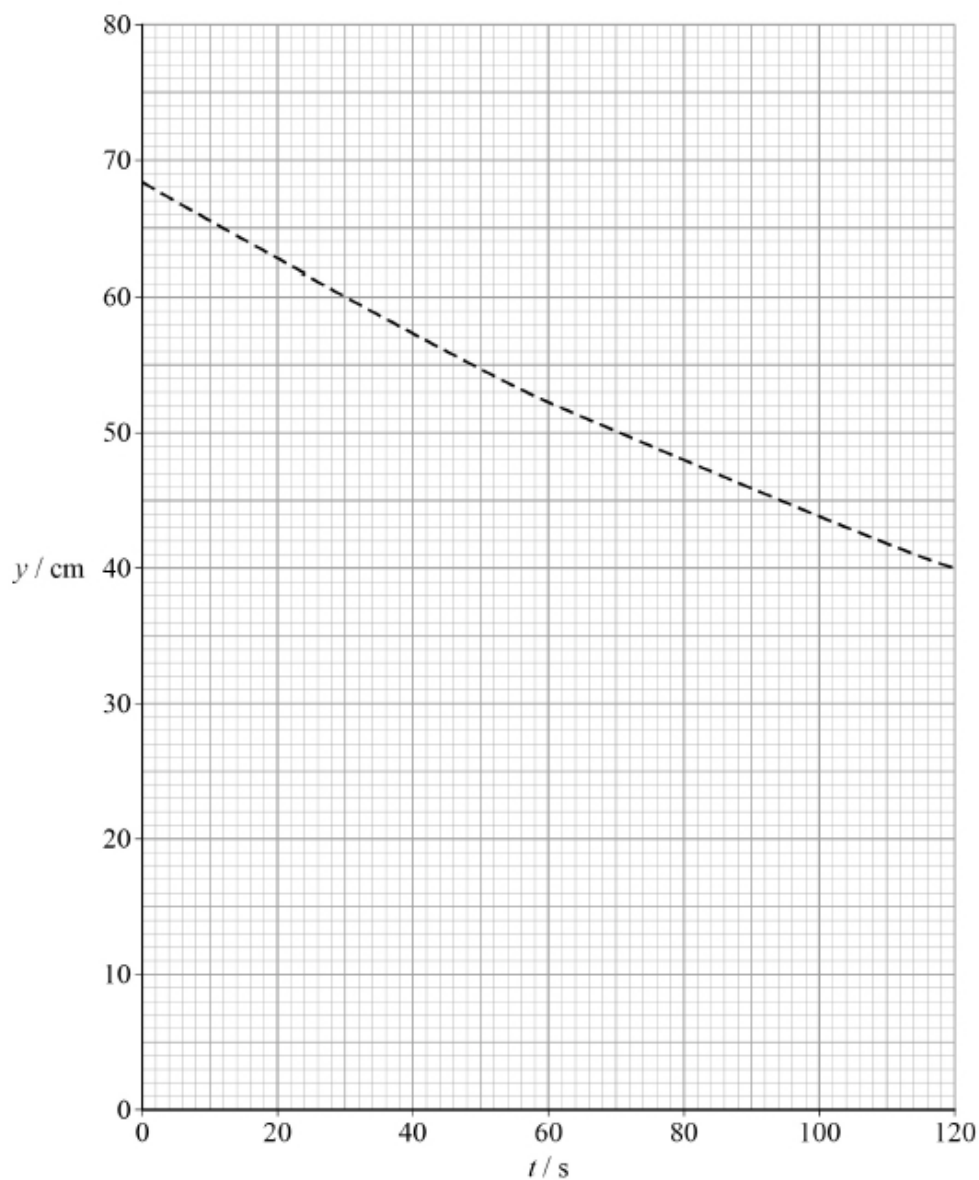

(2)

(Total 13 marks)

4. A student carries out an experiment to determine the resistivity of a metal wire. She determines the resistance from measurements of potential difference between the ends of the wire and the corresponding current. She measures the length of the wire with a ruler and the diameter of the wire using a micrometer. Each measurement is made with an uncertainty of 1%

Which measurement gives the largest uncertainty in the calculated value of the resistivity?

- A current
- B diameter
- C length
- D potential difference

(Total 1 mark)

5. Identical ring magnets **A** and **B** are arranged on a cylindrical wooden rod. The magnets' magnetic poles are on their largest faces. When placed with like poles in opposition, the magnets repel one another as shown in **Figure 1**.

The plan and sectional views in **Figure 1** identify the dimensions of these magnets. Each magnet has a circular cross-section and the central hole is circular.

Figure 1

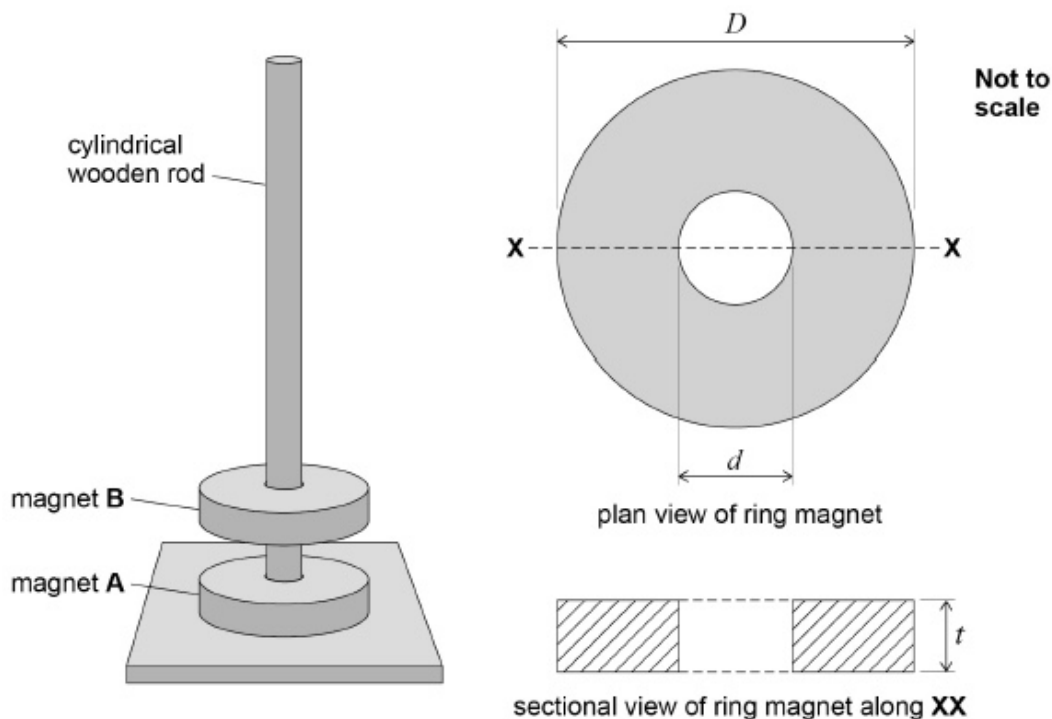

- (a) A student uses digital vernier calipers to find the external diameter  $D$  of magnet **B**, as shown in **Figure 2**.

**Figure 2**

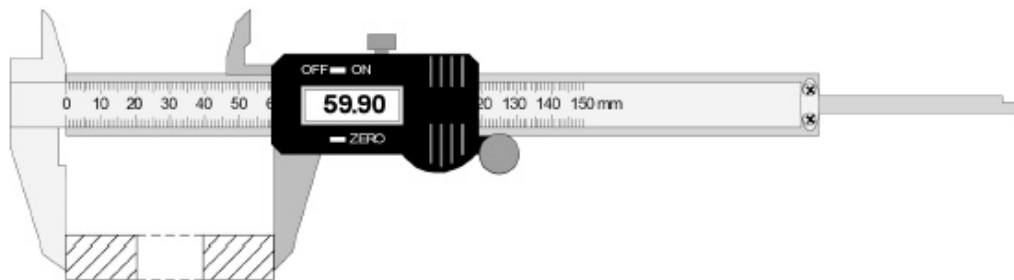

State precautions the student should take to reduce the effect of systematic and random errors when making this measurement.

Precaution to reduce effect of systematic error:

---

---

---

Precaution to reduce effect of random error:

---

---

---

(b) **Figure 3** shows the reading on the calipers as the internal diameter  $d$  is measured.

Draw the sectional view of magnet **B** on **Figure 3** to indicate how  $d$  is measured.

**Figure 3**

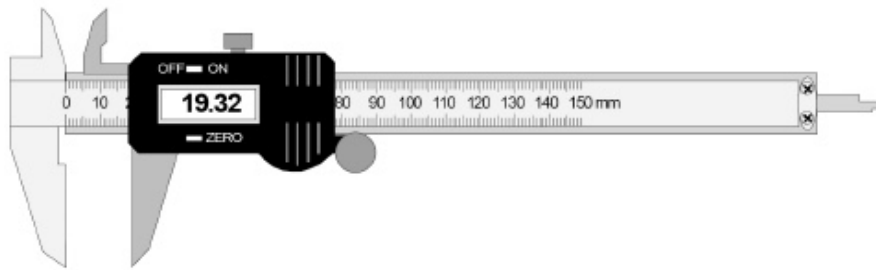

(1)

- (c) **Figure 4** shows the reading on the calipers when the thickness  $t$  of magnet **B** is measured.

**Figure 4**

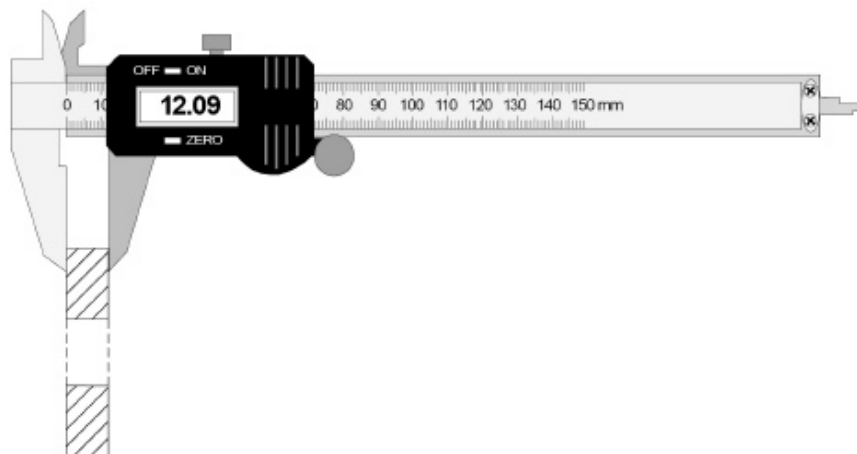

The readings that correspond to the dimensions of magnet **B** are shown in **Figures 2, 3** and **4**.

Calculate the volume of magnet **B**.

$$\text{volume} = \text{_____} \text{ m}^3$$

(3)

- (d) The student measures the mass  $m_B$  of magnet **B** and then positions the magnet so it is in equilibrium above magnet **A** as shown in **Figure 5**.  
The student measures the distance  $h$ .



Figure 5

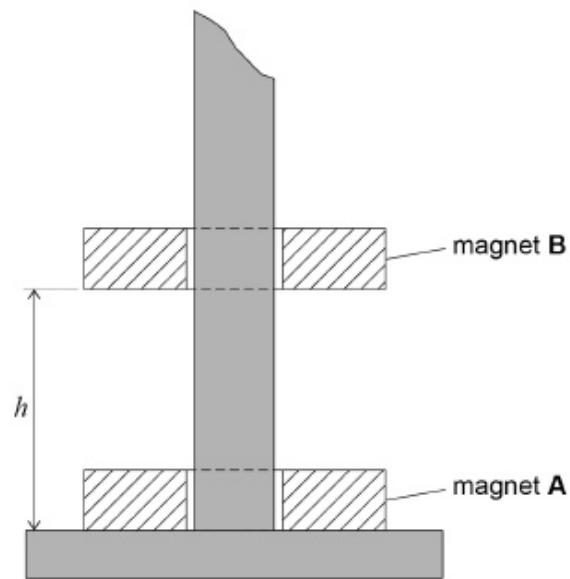

The student adds modelling clay to magnet **B** to reduce  $h$  by 50%.  
She measures the mass  $m_C$  of this clay.

She concludes that the force  $F$  exerted on magnet **B** by magnet **A** is given by  $F = \frac{k}{h^3}$   
where  $k$  is a constant.

Describe an experiment to test the student's conclusion that  $F = \frac{k}{h^3}$

Your answer should include:

- the procedure that could be used
- how the data produced could be analysed by a graphical method
- how the value of the constant  $k$  could be determined.

---

---

---

---

---

---

---

---

---

---

---

---

---

---

---

---

---

---

---

---

---

---

---

(5)  
(Total 11 marks)

6. **Figure 1** shows an arrangement used to investigate double slit interference using microwaves.  
**Figure 2** shows the view from above.

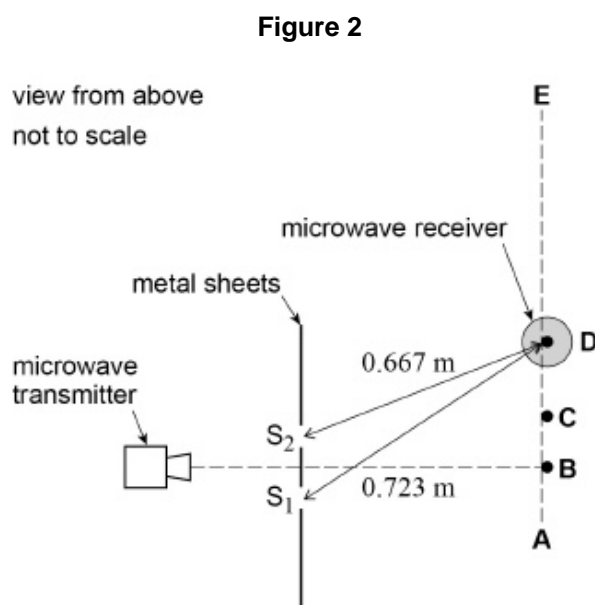
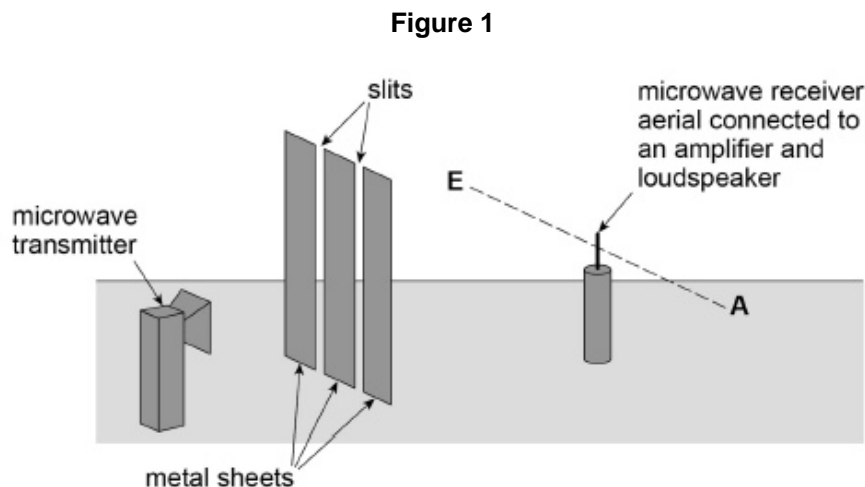

The microwaves from the transmitter are polarised. These waves are detected by the aerial in the microwave receiver (probe). The aerial is a vertical metal rod.

The receiver is moved along the dotted line **AE**. As it is moved, maximum and minimum signals are detected. Maximum signals are first detected at points **B** and **C**. The next maximum signal is detected at the position **D** shown in **Figure 2**.

**Figure 2** shows the distances between each of the two slits,  $S_1$  and  $S_2$ , and the microwave receiver when the aerial is in position **D**.  
 $S_1D$  is 0.723 m and  $S_2D$  is 0.667 m.

- (a) Explain why the signal strength falls to a minimum between **B** and **C**, and between **C** and **D**.

---



---



---

---

---

---

---

---

(3)

(b) Determine the frequency of the microwaves that are transmitted.

frequency = \_\_\_\_\_ Hz

(3)

(c) The intensity of the waves passing through each slit is the same.

Explain why the minimum intensity between **C** and **D** is not zero.

---

---

---

---

---

---

---

---

---

---

(2)

- (d) The vertical aerial is placed at position **B** and is rotated slowly through  $90^\circ$  until it lies along the direction **AE**.

State and explain the effect on the signal strength as it is rotated.

---



---



---



---



---



---

(3)

(Total 11 marks)

7.

A student performs an experiment to find the acceleration due to gravity. The student measures the time  $t$  for a spherical object to fall freely through measured vertical distances  $s$ . The time is measured electronically. The results are shown in the table below.

$s/m$	$t_1/s$	$t_2/s$	$t_3/s$	mean time $t_m/s$	$t_m^2/s^2$
0.300	0.245	0.246	0.244	0.245	0.0600
0.400	0.285	0.286	0.286	0.286	0.0818
0.500	0.319	0.321	0.318	0.319	0.102
0.600	0.349	0.351	0.348	0.349	0.122
0.700	0.378	0.380	0.378	0.379	0.144
0.800	0.403	0.406	0.404		
0.900	0.428	0.428	0.430		

(a) Complete the table by entering the missing values for  $t_m$  and  $t_m^2$

(1)

(b) Complete the graph below by plotting the remaining two points and draw a line of best fit.

(2)

(c) Determine the gradient of the graph.

---

---

---

---

---

(3)

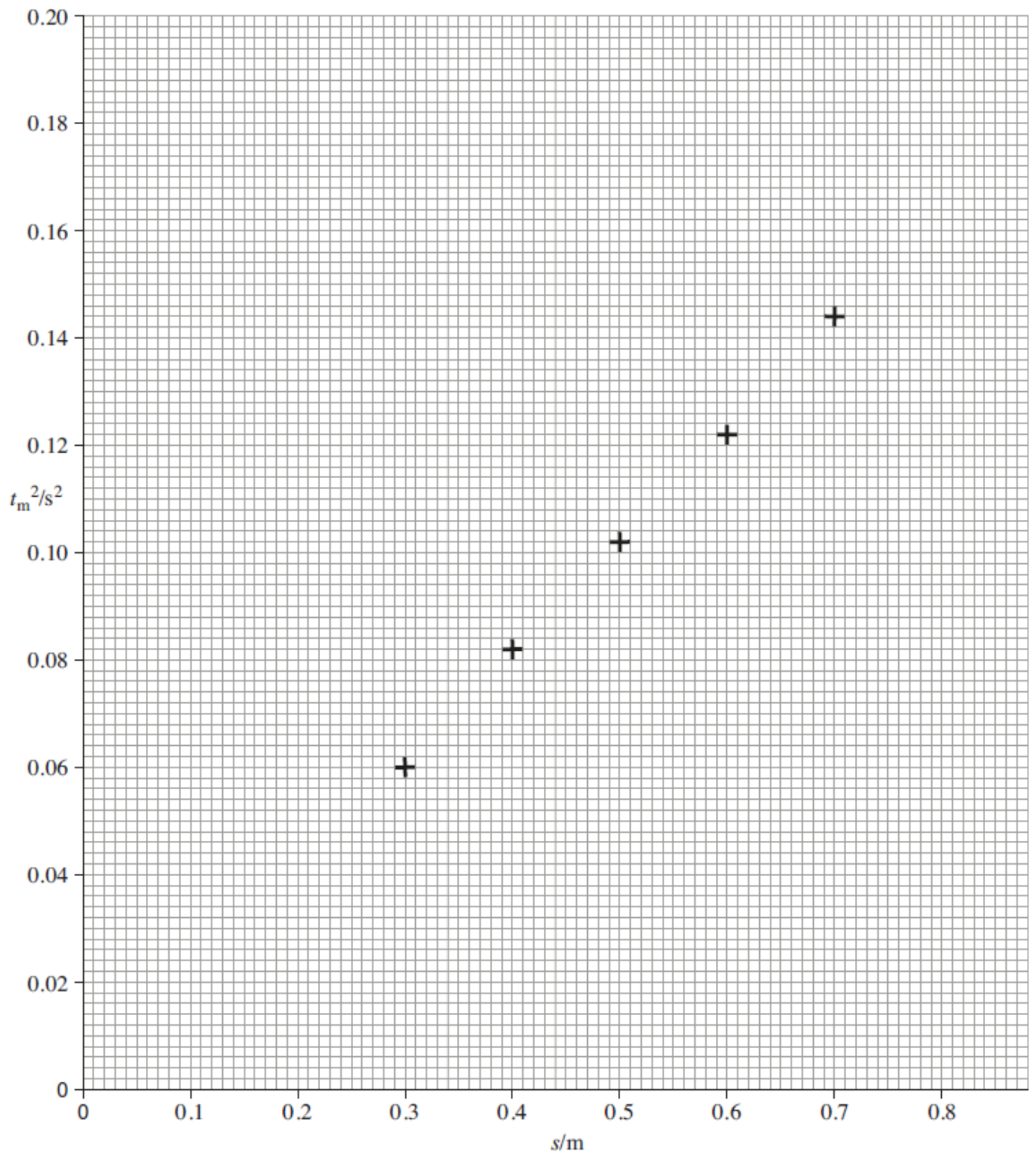

- (d) Theory suggests that the equation for the line is  $t^2 = \frac{2s}{g}$  where  $g$  is the acceleration due to gravity.

Calculate a value for  $g$  using the above equation and the gradient of your graph above.

---

---

---

---

---

(1)

- (e) Calculate the percentage difference between your value for  $g$  and the accepted value of  $9.81 \text{ m s}^{-2}$ .

---

---

---

---

(1)

- (f) Calculate the uncertainty in the smallest value of  $t_m$ .

---

---

(1)

- (g) Calculate the value of  $g$  which would be given from the smallest value of  $t_m$  and the corresponding value of  $s$ .

---

---

---

---

---

---

(3)



(h) The uncertainty in each value of  $s$  is  $\pm 0.001$  m.

Calculate the uncertainty in the value of  $g$  you calculated in part **(g)**.

You will need to use the uncertainty for  $t_m$  you calculated in part **(f)**.

---

---

---

---

---

---

---

---

**(3)**

- (i) A student wishes to investigate the effect of changing the mass of the spherical object on the acceleration of free fall.

Explain how you would modify the experiment seen at the start of this question.

---

---

---

---

---

---

---

---

---

---

---

---

---

---

---

---

---

---

---

---

---

---

---

(3)

(Total 18 marks)